

***These Modifications should be done by a qualified machinist or by Rufus Dawg*
You can contact Us at 1-866-783-8734**

REMOVE ALL INTERNAL PARTS BEFORE PROCEEDING WITH MODIFICATIONS

1. Bore a .740 dia Hole
.610 back from
designated Surface.

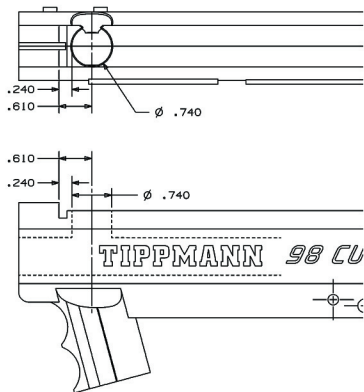

2. Use the CenterFeed as
a template to centerpunch
the sidehole.

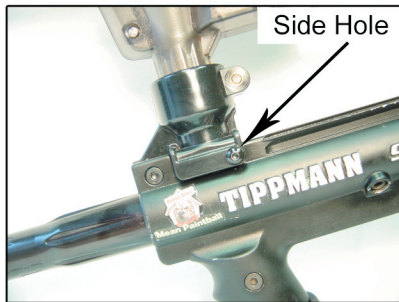

3. Drill and tap for a #6-32 Through
the left gun frame.