

# REG SIZES



3.5"



3.75"



4.125"



4.5"

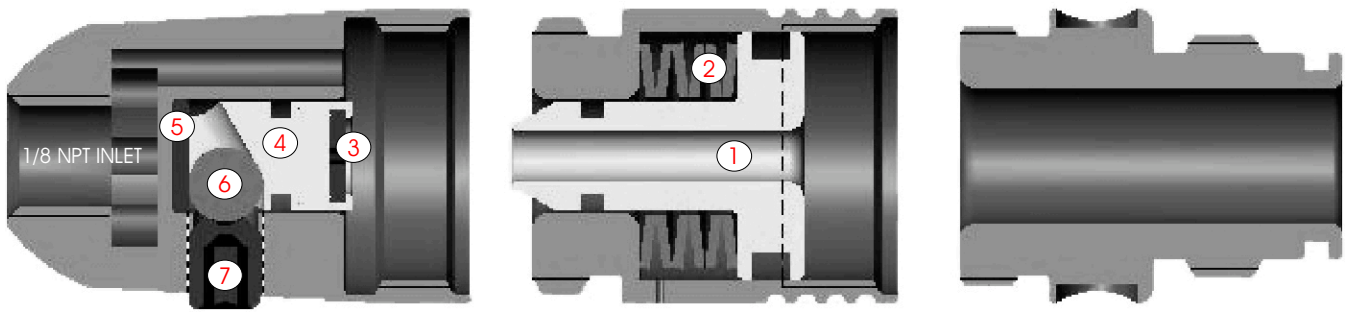

- ① PISTON ② DISC SPRING STACK ③ REG SEAT ④ SEAT CARRIER ⑤ SEAT CARRIER FLOOR ⑥ .250" BALL ⑦ ADJUSTMENT SCREW

- 1) **MAXIMUM INPUT PRESSURE LIMIT IS 900PSI.**
- 2) FOR OUTPUT OPERATING PRESSURES LESS THAN 200PSI ADJUST INPUT PRESSURE TO 500PSI FOR MAXIMUM PERFORMANCE.
- 3) **TURN ADJUSTMENT SCREW CLOCKWISE TO DECREASE PRESSURE UNTIL REGULATOR SHUTS OFF. REVERSE DIRECTION COUNTER CLOCKWISE TO INCREASE PRESSURE.**
- 4) FOR BEST ADJUSTMENT RESULTS, SHOOT YOUR MARKER WHILE SLOWLY TURNING SCREW COUNTER CLOCKWISE FROM THE OFF POSITION.
- 5) **ADJUST REGULATOR IN SMALL INCREMENTS UNTIL DESIRED PRESSURE OR VELOCITY IS ACHIEVED.** HIGH PRESSURE PISTONS ARE AVAILABLE FOR OPERATING PRESSURES OVER 500 PSI

**CUSTOM**  **PRODUCTS**  
**PAINTBALL**  
**USER MANUAL FOR GRIP REG**

**WARRANTY INFO:**

This Reg should give you years of flawless and consistent regulation. If by chance something should go wrong with this unit, CP will repair or replace this Reg for a period of **5 years**. (Warranty only applies to the original purchaser)

**Custom Products** 1640 W Sunrise Blvd Gilbert, AZ 85233 (480)539-4820 phn (480)497-3273 fx

You have just purchased a REG that we believe to have the highest and most consistent flow rate of any REG on the market. Thank You!!!