

OWNER'S MANUAL and DO'S AND DON'TS OF MARKER CARE

Contains:

- Safety Information
- Warranty Information
- Operating Instructions
- Annotated Diagram
- Trouble Shooting Guide

WARNING: THIS IS NOT A TOY. MISUSE MAY CAUSE SERIOUS INJURY OR DEATH. EYE PROTECTION DESIGNED FOR PAINTBALL USE MUST BE WORN BY THE USER AND ANY PERSON WITHIN RANGE. RECOMMEND AT LEAST 18 YEARS OLD TO PURCHASE, 14 YEARS OLD TO USE WITH ADULT SUPERVISION, OR 10 YEARS OLD TO USE ON PAINTBALL FIELDS MEETING ASTM-STANDARD F1777-02. READ OPERATION MANUAL BEFORE USING.

WARNING: NEVER SHOOT AT ANYONE WITHOUT PROPER PROTECTIVE EQUIPMENT FOR EYES, EARS, THROAT AND HEAD, WHICH MUST BE WORN AT ALL TIMES. EYE PROTECTION MUST BE DESIGNED SPECIFICALLY FOR PAINTBALL USE. FAILURE TO FOLLOW THESE SAFETY PRECAUTIONS MAY RESULT IN BODILY INJURY INCLUDING BLINDNESS AND DEAFNESS.

Welcome to the Viewloader® team and thank you for purchasing this high quality Viewloader® paintball marker.

We at Viewloader® stand committed to providing you with the best product and service available. Your new marker is designed and manufactured to provide ease of maintenance with trouble free performance. We ask that you read this manual to obtain the maximum enjoyment and safety of your purchase.

Call 1-877-877-GAME (4263) or visit our web site at www.viewloader.com/service if you should need an Illustrated Parts List.

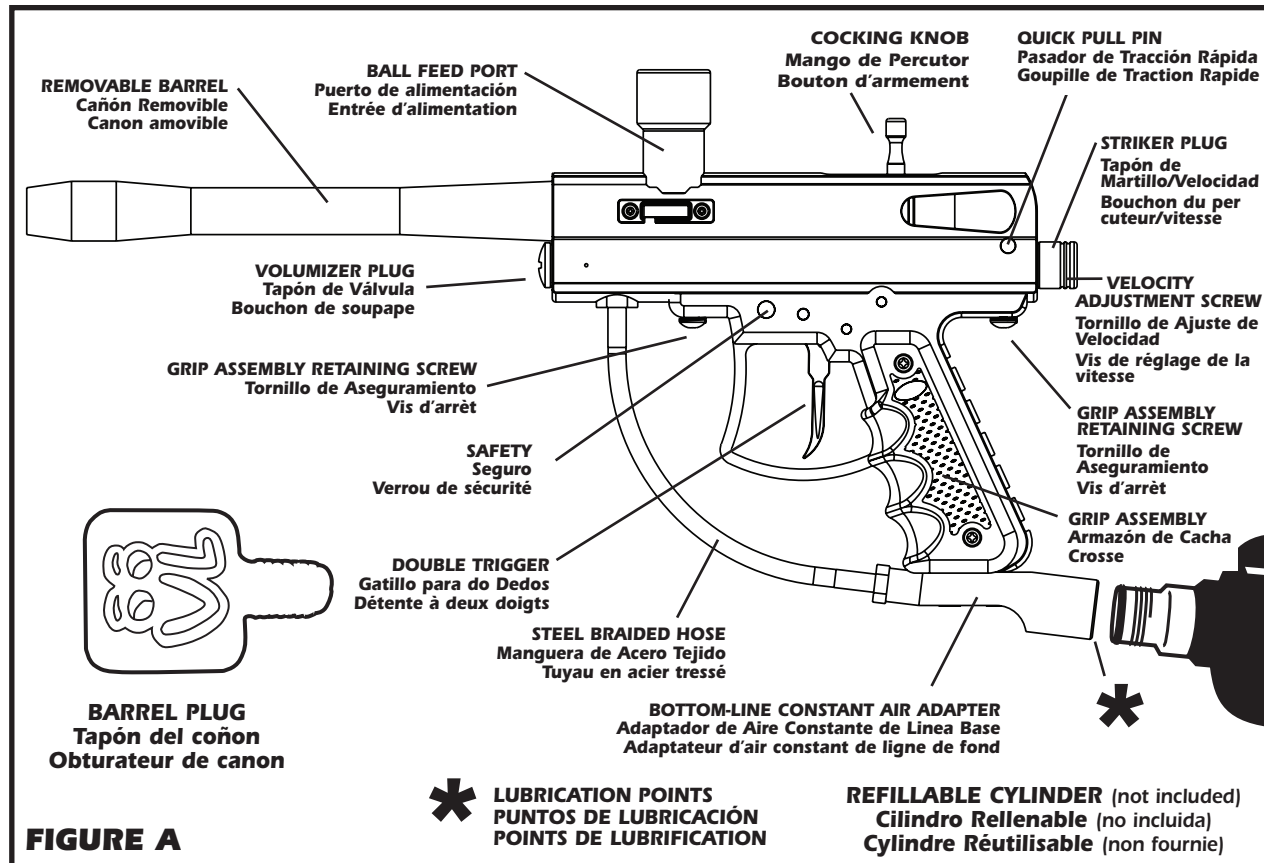
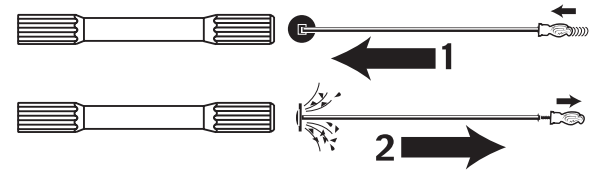

FIGURE A

Use a chronograph to insure the marker's velocity is set accurately. We recommend the Viewloader® On-Barrel Chronograph #7815 to verify velocity.

Use a barrel squeegee to clean broken paintballs from your marker's barrel. We recommend the Brass Eagle® Combo Barrel Squeegee #1477 or Viewloader® Proflex Squeegee #5012.



DO NOT RETURN THIS MARKER TO YOUR RETAILER. FOR ASSISTANCE CALL 1-877-877-GAME (4263). WARRANTY INFORMATION

WARRANTY: LIMITED 90 DAY WARRANTY (ORIGINAL PURCHASE RECEIPT REQUIRED)

For 90 days from date of purchase, Viewloader® will repair or replace this marker free of charge if defective in material or workmanship. This warranty gives you specific legal rights. You may also have other rights which may vary from state to state. Service is available from authorized Viewloader® Service Centers. A list of these is available at Viewloader's website at www.viewloader.com or by calling Viewloader® at 1-877-877-GAME (4263). These Service Centers generally offer the quickest service.

If you would rather return your marker to Viewloader® please call customer service at 1-877-877-GAME (4263) for return authorization number and shipping address. (Authorization number must be visible on outside of shipping package to be accepted.)

Do not return any products via non-trackable services such as regular mail or parcel post. Such products may become lost and Viewloader® Inc. will not be responsible for replacement.

PAINBALL MARKERS OUT-OF-WARRANTY

Authorized Service Centers will gladly repair any markers out of warranty for a nominal charge to cover parts and labor. Repairs made by Service Centers will usually be faster and less expensive than those sent back to the factory. Go to www.viewloader.com/service for service center locations near you. **Prior to shipping out of warranty markers, you must first call customer service at 1-877-877-GAME (4263) for return authorization number and shipping address. (Authorization number must be visible on outside of shipping package to be accepted.)** Any out of warranty Marker returned to Viewloader® must be shipped prepaid and include the repair fee. Please call the Customer Service number for current repair fees. Viewloader® will repair or replace the marker with a reconditioned unit of the same model. If payment is not included, you will be billed for the repair fee plus a \$4.00 invoicing fee. Upon receipt of payment, the marker or its replacement will be shipped to you. In the event that the marker includes no means of contacting the sender or no payment for repairs is received within 60 days of billing, the ownership of the marker will be forfeited and it will be disposed of at the discretion of Viewloader® Inc.

SPECIAL INSTRUCTIONS Maintenance/Operation

Follow all procedures listed in this manual. In addition, periodically check the steel braided hose assembly for leaks or fraying.

Safety

Do not allow the steel braided hose to be pinched in any way. The hose is durable but is not intended to act as a trigger guard.

FIELD STRIP GUIDE Bolt and Striker removal

STEP 1. EYE PROTECTION: Make sure everyone within range (200 yards) is properly protected from paintball impacts.

STEP 2. Remove gas supply from marker.

STEP 3. Make sure cocking bolt is in the forward position. Pull trigger to release if necessary.

STEP 4. Remove Quick Pull Pin and Remove Velocity Plug, Bumper, Spring Guide, Spacer, and Spring Striker and Bolt (Figure B). NOTE: Use caution when removing as all parts are under spring tension.

FIELD STRIP REASSEMBLY

Follow the steps above in reverse order. Lubricate all wear points and o-rings with mineral oil only.

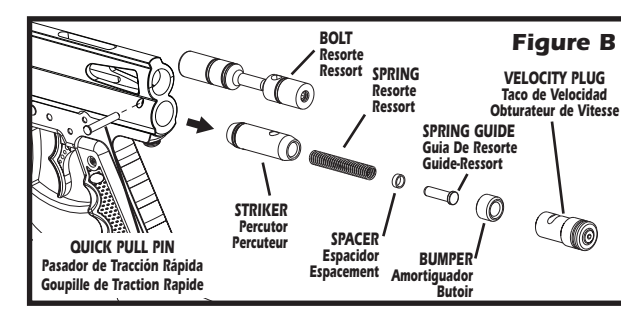

STRIKER REMOVAL / REPLACEMENT

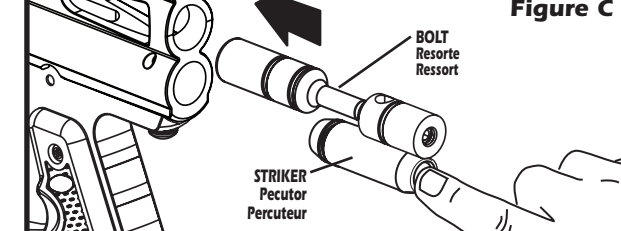

STEP 1. Follow Steps 1-5 of Field Strip Guide.

STEP 2. Pull trigger and tap rear of the receiver against towel on flat surface to remove striker.

STEP 3. Grasp striker with fingers and pull from receiver.

STEP 4. Clean with soft cloth or baby wipe. Relubricate with mineral oil and replace. NOTE: Examine o-ring for any damage and replace if necessary.

STEP 5. Replace striker bolt assembly into receiver with sear flat down. NOTE: It is necessary to pull the trigger 3 or more times while applying pressure to striker bolt assembly with your finger in order to fully seat the striker. (See Figure C)

STEP 6. Reassemble per Field Strip Reassembly Section.

DISASSEMBLY / CLEANING OF BALL DETENT

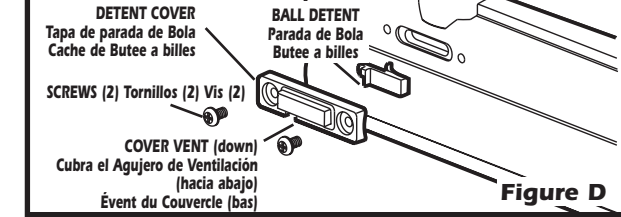

STEP 1. Remove 2 Phillips head screws.

STEP 2. Remove ball detent and cover.

STEP 3. Clean with soft cloth or baby wipe.

STEP 4. Replace in reverse order insuring the detent tip is toward barrel and the detent cover vent is facing downward. (See Figure D)

DO'S AND DON'TS OF CARE AND MAINTENANCE

Note: Any cosmetic or mechanical changes to product will void warranty. Follow these easy points to keep your marker in top shape for years to come.

DO'S

- DO read owners manual thoroughly before using marker and for complete disassembly and cleaning instructions.
- DO lubricate o-rings using 3 drops of mineral oil in the ASA adapter with each change of gas source (tank), or marker will dry out and cause it to not cock after the first shot or after rapid firing.
- DO examine valve seal drawing on back to insure correct reassembly.
- DO familiarize yourself with the parts drawing prior to any disassembly.
- DO put marker parts on cloth to avoid losing parts or parts falling down onto dirt or sand when disassembling.
- DO lubricate o-rings with mineral oil immediately after cleaning. See backside for lubrication points.

DON'TS

- DON'T return this marker to retailer. Call 1-877-877-GAME (4263).
- DON'T DISASSEMBLE marker if you are unfamiliar with marker maintenance. (Call customer service at 1-877-877-4263 or visit our website at www.viewloader.com/service for assistance).
- DON'T use lubricants other than mineral oil. (For questions about proper lubricants consult the web page or customer service at 1-877-877-4263)
- DON'T disassemble hose from marker. (Call customer service at 1-877-877-4263 for assistance).

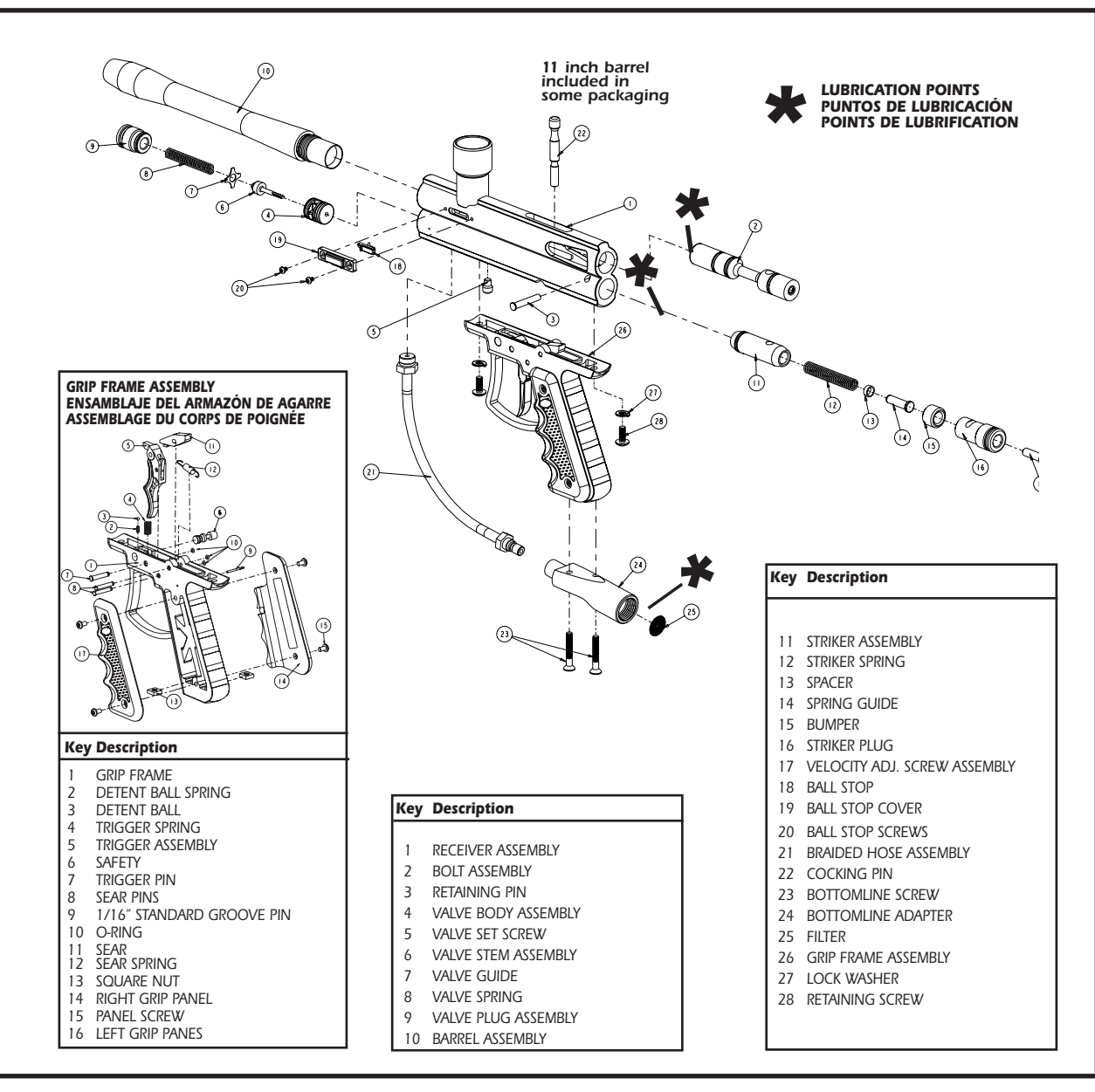

• DONT immerse marker in water. (Marker parts may be cleaned by wiping with a soft cloth or paper towel).

TROUBLESHOOTING GUIDE		
PROBLEM	CAUSE	CURE
Gas Leaks from Cylinder Connection	Damaged Cylinder O-ring	Replace O-ring
Gas Leaks from Inside Barrel	Damaged Valve Seal	Replace Valve Stem Assembly
Marker Fails to Discharge	Marker Wasn't Cocked	Cock Marker Before Firing
	Lack of Gas Pressure	Refill Cylinder
	Lack of Lubricant or Paintball Debris	Refer to Field Strip Guide Section
	Gas Source Not Fully Engaged	Screw Gas Source into Bottom Line Constant Air Adapter.
Marker Fails to Recock	Damaged Striker O-ring	Replace Striker O-ring
	Lack of Gas Pressure	Refill Cylinder
Rapid Fire or Mechanism Sticks or Hangs Up	Broken Shell	Clean Mechanism
	No Lubrication	Lubricate Bolt and Striker
Broken Paintballs	Excessive Paint Buildup in Barrel	Squeegee out paintball particles from barrel
	Defective Paintballs	Replace Paintballs

Additional Troubleshooting Tips, Repair Kit and Parts Exploded view are available on our website at: www.viewloader.com/service.

The VL Repair Kit #0034-00 is available at your local retailer or on our website at: www.viewloader.com

OPERATING INSTRUCTIONS

WARNING: Be sure the paintball marker is always pointed in a safe direction. Read the following operating instructions and WITHOUT LOADING ANY PAINTBALLS proceed several times through the operating steps with your paintball marker (dry fire the paintball marker at a safe target) so that you will be able to operate the marker properly and safely.

STEP 1. EYE PROTECTION: Make sure everyone within range (200 yards) is properly protected from paintball impacts.

STEP 2. PUT ON "SAFE". Push safety from left to right; no red band showing. Make sure barrel plug is placed securely in muzzle of marker

STEP 3. COCK: Cock marker by pulling cocking handle fully back until locked in sear position. This marker is a semi-automatic marker, which will re-cock itself after firing when working properly.

STEP 4. ATTACH GAS SOURCE: Marker can be used with a Brass Eagle® constant air refillable cylinder (not included). You should expect better gas efficiency with a larger refillable cylinder. (RECOMMEND Brass Eagle® 9oz. refillable cylinder. Item #1471.)

NOTE: Add 3 drops of mineral oil to the ASA adapter prior to attaching the refillable cylinder. Check the website at: www.viewloader.com/service for approved lubricants.

STEP 5. LOAD PAINTBALLS:

A) Insert loader (not included with all packaging) into ball feed port. Grip loader from the top. Insert loader feed neck into ball feed port on the marker. Twist and push firmly in a clockwise direction.

NOTE: The loader to ball feed port fit is purposely tight. (RECOMMEND Viewloader® Quantum™, eLu-tion™ or Revolution™ electronic loader)

B) Pour paintballs into loader. NOTE: Paintballs are gravity fed from loader to the marker each time the trigger is pulled. Too rapid a rate of fire, broken balls or too many balls in loader may cause subsequent balls to break and will adversely affect the paintball marker's accuracy. Use a squeegee to clean inside the paintball marker's barrel. (RECOMMEND Brass Eagle®, Viewloader® JT®, or WGP® brand .68 caliber paintballs.) Paintballs should be stored in a cool, dry place in sealed plastic bags. Do not subject to freezing, excessive heat, humidity or store in direct sunlight. These conditions may cause ball breakage and/or poor feeding.

STEP 6. Remove barrel plug and take off safe by pressing safety from right side of paintball marker until red band is showing.

STEP 7. VERIFY VELOCITY: Verify that the paintball marker's velocity is below 300 feet per second or less if required by playing field. Velocity should be measured with a chronograph prior to playing paintball. Velocity may be adjusted by turning the velocity adjustment screw (See Fig. A) Using a 1/8" allen key (included) turn the screw clockwise to increase velocity and counter-clockwise to decrease velocity. (RECOMMEND Viewloader® on-barrel chronograph to verify velocity. Item #7815.) NOTE: Additional velocity adjustment available by adding or removing striker spring spacer. (Fig. B)

STEP 8. FIRE: Paintball marker is now ready to fire.

WARNING: Never shoot at anyone without proper protective equipment for eyes, which must be worn at all times. Eye protection must be designed specifically for paintball use. Failure to follow these safety precautions may result in bodily injury including blindness and deafness.

UNLOADING YOUR MARKER

WARNING: Always wear proper eye, face and ear protection designed especially to stop paintballs while unloading your paintball marker.

STEP 1. Make sure barrel plug is securely in barrel.

STEP 2. Put Marker on safe. (Push left to right)

STEP 3. Remove loader.

STEP 4. Turn marker upside down to remove paintballs from feed port.

STEP 5. Remove barrel.

STEP 6. Point marker toward ground in a safe direction and fire several times to insure it is completely unloaded. Put marker back on safe.

STEP 7. Remove gas source.

STEP 8. Use squeegee to dislodge any paintballs from barrel and replace barrel plug.

STEP 9. Replace barrel.

Do not unload your marker indoors.

WARNING: Do not look down the breach or barrel of the marker while gas source is attached.

PO. Box1956, Rogers, AR 72757, U.S.A.
877-877-GAME(4263) Fax (727)464-8701
www.viewloader.com

