

autococker



advanced paintball marker

owners manual





Table of contents

- 1. SAFETY GUIDELINES
 - a. RULES OF SAFE PAINTBALL MARKER HANDLING
 - b. High pressure tank warning
-

- 2. QUICK START
 - Tools needed
 - a. Installing s 9V battery
 - b. Switching Marker ON
 - c. Firing
 - d. Checking and Testing the Break Beam Eyes
 - e. Switching Marker OFF
 - f. Attaching barrel and barrel sock
 - g. Attaching air source
 - h. Attaching loader
 - i. Firing and adjusting velocity

- 3. THE AUTOCOCKER SR
 - Electronic Features
 - Mechanical Features
 - 12 Fire Modes
-

- 4. PCBA OPERATION AND PROGRAMMING
 - a. Features
 - b. LED and OLED Indicator
 - c. Power
 - d. Eye Operation and Logic
 - e. Eye Modes
 - f. Program
 - g. Settings
 - h. Program Examples
 - i. Additional Features
-

- 9. MAINTENANCE
 - a. Operation
 - b. Maintenance
-

12. SCHEMATICS

17. SPARES & ACCESSORIES

18. TROUBLESHOOTING GUIDE

18. FAQ

19. SERVICE CENTER

19. WARRANTY INFORMATION

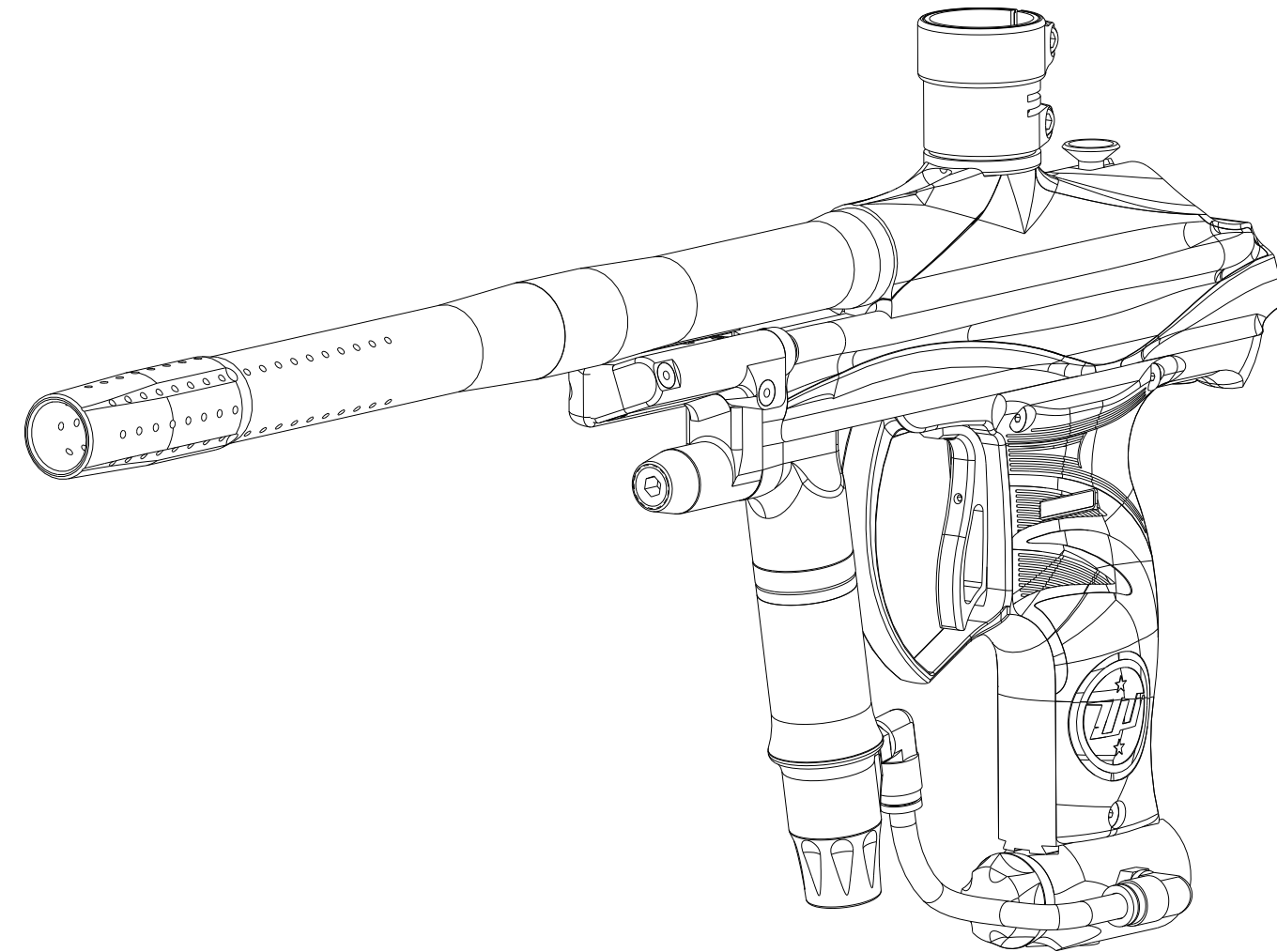

rules of safe paintball marker handling

1. Always wear proper eye, face and ear protection designed especially to stop paintballs.
2. Never shoot a person who is not wearing proper protection.
3. Treat every paintball marker as if it were loaded.
4. Never look down the barrel of the marker.
5. Never point the paintball marker at anything you don't wish to shoot.
6. Keep the paintball marker on safe until ready to shoot.
7. Keep the barrel plug in the paintball marker's muzzle when not shooting.
8. Always remove gas source before disassembly.
9. Store the paintball marker unloaded and degassed in a locked place.
10. Follow warnings listed on gas source for handling and storage.
11. Never use anything other than .68 caliber paintballs.
12. Do not shoot fragile objects such as windows.
13. Paintballs may cause staining of some porous surfaces such as brick, stucco and wood.
14. Always measure velocity before playing paintball.
15. Never shoot at velocities in excess of 300 feet per second.
16. Never engage in vandalism.
17. Do not use marker for drive-by shootings.
18. Do not modify your marker's pressurized air system or cylinder in any way.

WARNING: THIS IS NOT A TOY. MISUSE MAY CAUSE SERIOUS INJURY OR DEATH. EYE PROTECTION DESIGNED FOR PAINTBALL USE MUST BE WORN BY THE USER AND ANY PERSON WITHIN RANGE. RECOMMEND AT LEAST 18 YEARS OLD TO PURCHASE, 14 YEARS OLD TO USE WITH ADULT SUPERVISION, OR 10 YEARS OLD TO USE ON PAINTBALL FIELDS MEETING ASTM-STANDARD F1777-02. READ OPERATION MANUAL BEFORE USING.

WARNING: NEVER SHOOT AT ANYONE WITHOUT PROPER PROTECTIVE EQUIPMENT FOR EYES, EARS, THROAT AND HEAD, WHICH MUST BE WORN AT ALL TIMES. EYE PROTECTION MUST BE DESIGNED SPECIFICALLY FOR PAINTBALL USE. FAILURE TO FOLLOW THESE SAFETY PRECAUTIONS MAY RESULT IN BODILY INJURY INCLUDING BLINDNESS AND DEAFNESS.

⚠ PÉRIL
⚠ DANGER
⚠ PELIGRO

HIGH PRESSURE ALUMINUM ALLOY CYLINDER
BOUTEILLE À HAUTE PRESSION EN ALLIAGE D'ALUMINIUM
CILINDRO DE ALEACIÓN DE ALUMINIO PARA ALTA PRESIÓN

VALVE
CLAPET
VÁLVULA

CYLINDER
CYLINDRE
CILINDRO

The cylinder can fly off with enough force to kill if the valve unscrews from the cylinder.

- STOP if valve starts to unscrew from the cylinder. Screw it back on and take it to a trained person for repair.

EXPLOSION HAZARD: Improper use, filling, storage or disposal may result in property damage, serious personal injury, or death.

- This cylinder must be filled only by properly trained personnel in accordance with CGA Pamphlets P-1, C-6, G-6.3 and AV-7 available from the Compressed Gas Association, 4221 Walney Rd., Chantilly, Virginia 20151-2923
- Valves must be installed and removed only by trained personnel.
- Do not overfill cylinder. Do not exceed the pressurized rating stamped on your cylinder.
- Do not expose to temperatures exceeding 130°F when pressurized.
- Do not use caustic cleaners or strippers.
- Do not modify this cylinder or valve in any way.
- Cylinder will be destroyed if exposed to fire or heated to a temperature exceeding 350° F.
- Keep cylinder out of reach of children.

quick start

Warning: Be sure the paintball marker is always pointed in a safe direction. Read the following operating instructions and WITHOUT LOADING ANY PAINTBALLS proceed several times through the operating steps with your paintball marker (dry fire the paintball marker at a safe target) so that you will be able to operate the marker properly and safely.

Eye Protection: make sure everyone within range (200 yards) is properly protected from paintball impacts.

Tools Needed:

- 3/16" Allen key for velocity adjustment
- 1/16" Allen key for trigger adjustments
- 5/64" Allen key for grip panel / battery installation.
- 5/32" Allen key for feed neck tightening

A. Installing a 9V Battery: Use a 5/64" Allen key and remove the 3 screws on the left grip panel. Pull the grip panel out to reveal the battery clip. Install a single 9 volt battery (not included) to the battery clip and install in the marker. Reassemble the left grip panel and tighten screws. PRO TIP: High performance (fast shooting) paintball markers work better with high quality batteries.

B. Switch the marker ON by pressing the rear push button located on the back of the grip frame. Back LED will light up RED and BLUE momentary and then solid BLUE. OLED will also display mode, battery indicator, and rate of fire (ROF). The Break Beam Eyes will be ON. Warning: Marker is live and ready to fire.

C. Firing: pull the trigger and marker will make a "click" sound indicating a fire. With the Break Beam Eyes ON, the marker will sound slow which is normal. To turn the Break Beam Eyes OFF, press the rear push button located on the back of the grip frame and hold for 1.5 seconds. When you see the back LED turn solid RED, release the push button. Pull the trigger and marker will make a "click" sound indicating a fire. With the Break Beam Eyes OFF, marker should sound much faster. To turn the Break Beam Eyes ON, press the rear push button and hold for 1.5 seconds. When you see the back LED turn solid BLUE, release the push button.

D. Checking and Testing the Break Beam Eyes: When you first turn the marker ON, the Break Beam Eyes will be on and ready, rear grip frame LED will be solid BLUE. With the Break Beam Eyes ON, pull the bolt back past the eye sensor. The LED on the rear of the grip frame will flash BLUE indicating the eyes are functional. Push the bolt forward blocking the eyes and the LED will light up solid BLUE. Your Break Beam Eyes are functioning and ready for use. NOTE: you can not check and test for eye function when you turn the Break Beam Eyes OFF (solid RED LED on rear of grip frame), turn the eyes ON first before testing. If eyes are not functioning properly, go to troubleshooting guide.

E. Switching the marker OFF by pressing and holding the rear push button for at least 3 seconds, the OLED screen and rear LED will turn OFF signifying that the marker is OFF.

F. Attach your barrel. Now attach the barrel sock by sliding the cover over the barrel and attaching the strips to the marker's feedneck or the rear of the frame. It is very important that the barrel sock be attached when in an area where people are not wearing protective gear. Using the barrel sock correctly is a very important paintball safety practice.

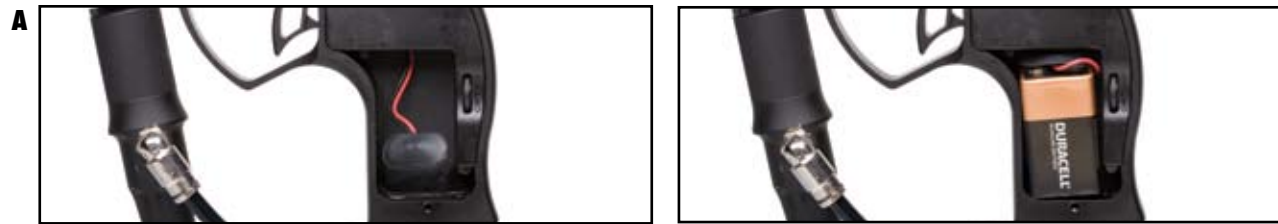

G. Confirm marker is OFF prior to tank/air source install. Once you have a full compressed gas cylinder (High Pressure Compressed Air recommended) attach the cylinder to the marker via the Bottom Line Air Source Adaptor (ASA) at the bottom of the grip frame. Screw the cylinder all the way into the ASA until it stops. Turn the bottom line ON/OFF screw clockwise all the way in to pressurize the marker.

H. Attaching the loader is simple and will require a 5/32" Allen HEX key. Unscrew the top screw on the clamping feed neck. Now attach the loader to the marker via the clamping feed neck by press fitting the loader neck down into the feed neck. Note: make sure the loader is pushed all the way down. Now tighten the screw on the feed neck so that the loader is held securely in place and also make sure the screw holding the feed neck to the marker is secure.

I. Firing paintballs and adjusting velocity: Before testing/adjusting velocity you must put on your paintball goggle system, fill loader with paintballs and turn your loader ON (if electronic). Always keep your marker pointed in a safe direction. Always keep your marker OFF and barrel cover on until you are ready to fire. When safe and ready to fire, remove barrel cover and turn marker ON. Pull the trigger and fire the marker. Organized paintball fields require markers to be chronographed to measure velocity. Your marker is preset to under 300 feet per second. Adjust the velocity with a 1/4" Allen key by turning the HP regulator adjustment screw. Never adjust your velocity above 300 feet per second. Velocity may also be adjusted by turning the IVG cap on the back of the marker. With a 3/16" Allen key (included) turn the IVG in clockwise to turn the velocity up. Additional detailed info available in the following owner's manual. Follow all rules specified by your organized paintball field. You are now ready for play. BE SAFE and HAVE FUN!

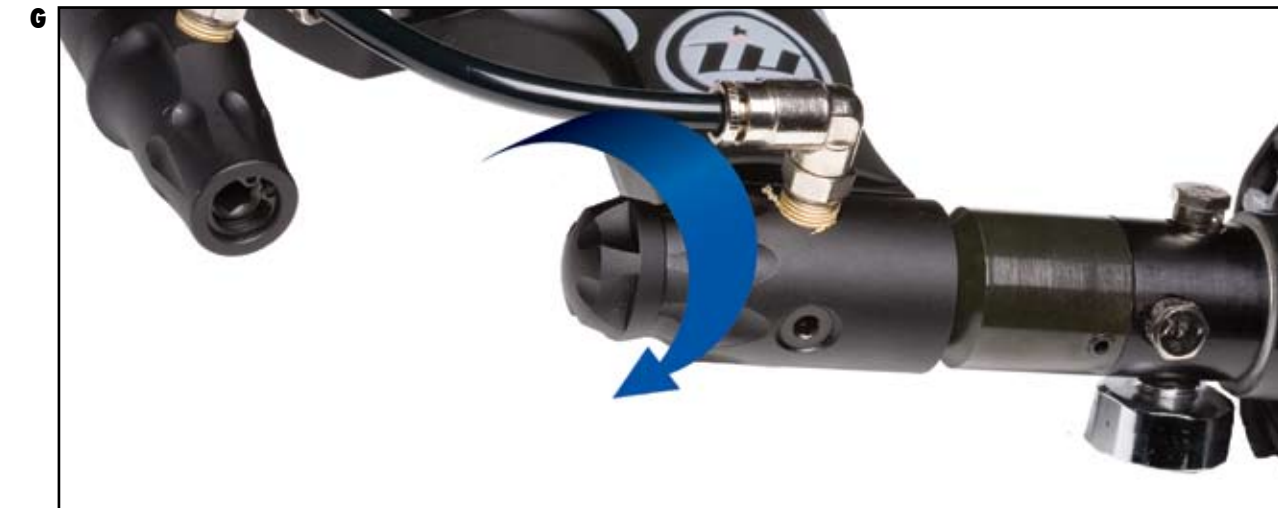

The autococker sr

The latest addition to the WGP family of quality markers, the completely redesigned Autococker SR now brings superior speed and reliability into its operating performance with high performance rates of fire capable of exceeding 25+ BPS. The SR features include:

Electronic Features:

1. Quick Dial™ thumb dial knob for easy access to programming and fire modes.
2. OLED display screen
3. Break beam eyes with manual on/off
4. Completely programmable function and adjustments including: Debounce, Cycle percentage filter, Anti-mechanical bounce, Ball in Place delay, Max rate of Fire, Ramp start, Breakout

Mechanical Features:

1. Closed bolt accuracy.
2. Ergonomic grip frame assembly
3. High speed MP5 ram assembly with integrated TRV (Turbo Relief Valves)
4. Redesigned front pneumatics assembly eliminating low pressure hoses
5. Dual soft rubber ball stops.
6. Gasket sealed front block.
7. Macroline quick release hose.
8. Internal pump rod.
9. Adjustable low and high pressure regulators
10. On/Off bottom line.
11. Clamping feed-neck.
12. 14" 2 piece barrel.
13. Fully adjustable trigger.
14. Quick release pull pin.
15. Redesigned light weight delrin bolt.

12 Fire Modes:

- Mode 1 semi-automatic with an unlimited rate of fire
- Mode 2 semi-automatic with an adjustable rate of fire
- Mode 3 PSP auto-response
- Mode 4 PSP 50% ramping
- Mode 5 PSP 100% ramping
- Mode 6 PSP burst
- Mode 7 NXL full-automatic
- Mode 8 auto-response
- Mode 9 50% ramping
- Mode 10 100% ramping
- Mode 11 3 round burst
- Mode 12 full-auto

paint operation and programming

Features:

- Fully functional including 12 fire modes: uncapped semi-auto, capped semi-auto, PSP auto-response, PSP 50% ramping, PSP 100% ramping, PSP burst, NXL full-automatic, auto-response, 50% ramping, 100% ramping, 3 round burst, and full-automatic
- Trigger switch monitors, using an interrupt based scan.
- AMB (anti-mechanical bounce) and CPF (cycle percentage filter) algorithms help to eliminate mechanical bounce and switch bounce
- Programming mode allows changes to DEBOUNCE, SEAR ON, BIP DELAY, AMB, FIRE MODE, MAX ROF, CPF, RAMP START, BREAK OUT, OPEN DELAY, WATCH TIME, CLOSE TIME, and EYE OFF ROF.
- All settings are stored in non-volatile memory so they are not lost when battery is disconnected
- One-touch startup enables the marker to fire instantly
- Automatic idle power down saves batteries
- Eye ON and OFF indicators
- Low battery indicator hardware and software shows battery level each time the marker is turned on

LED and OLED Indicator: (Figure 1)

The multi-color LED on the rear of the grip frame shows which mode of operation the marker is currently in:

Solid Blue, ready to fire

Slow Blinking Blue, used to check if eyes are working

Solid Red, Eye OFF, max rate of fire reduced to current user set

Power: ON/OFF is handled by the rear power button at the back of the frame. Pressing it instantly boots the marker, and will show a BLUE LED for eyes enabled. The OLED screen will show the current fire mode and the current Rate of Fire (ROF). The marker is ready to fire. Power OFF by pressing the rear power button and hold down for at least 3 seconds until the LED and OLED turns OFF, then release.

Eye Operation and Logic : (Figure 2)

The break beam eyes are used to increase speed and prevent chopped paintballs. When used, the marker will cycle as fast as possible. The eyes are enabled when the marker is first turned ON. Rear LED should be BLUE. OLED screen will display the current fire mode and the current eye ON ROF.

-To turn the eyes OFF, press the rear power button and hold for 1.5 seconds and release when rear LED turns RED. When eyes are OFF, the rear LED will be RED and the OLED will display current fire mode and the eyes OFF ROF. NOTE: When the eyes are off, the rate of fire is limited and adjustable from 10 to 25 balls per second.

-To turn the eyes back ON, press the rear power button and hold for 1.5 seconds and release when rear LED turns BLUE. OLED screen will revert back to eye ON display.

Eye diagnostics check: (Figure 3)

Note: We recommend this be done prior to hopper and tank install, confirm that the marker is not pressurized. Turn the marker ON. The rear LED should be a solid BLUE. Pull the pull pin up half way and slide the bolt back. Once you slide the bolt past the eyes, the rear LED should now blink BLUE indicating that the eyes are good. Now slide the bolt back forward and confirm that the LED is now solid BLUE. Realign the bolt and pull pin with the slide and push the pull pin all the way down until the ball detent inside of the bolt retains the pin. Note: If the LED does not change when you move the bolt back, this means that there is something blocking the eyes or your eyes are faulty. Go to eye cleaning section.

Eye Modes – Two eye modes are available:

1. ON – Used to fire the marker as fast as possible minimizing and eliminating chop balls. The ASR is a closed bolt system so unlike open bolt systems, the ASR will fire if there is no ball in the breach. Once fired, the logic will hold the bolt open a period of time to allow a ball to fully drop into the breach. Once the ball is fully breeched, the bolt will close and be ready for the next firing sequence. Note: If you are attempting to fire the marker with out balls, the marker will feel slow. There is nothing wrong with the marker. It should be slow because there is a time that is setup in the program to allow a ball to drop into the breach. This time is adjustable and would only be recommend being adjust lower if a high speed loader is available, for example a View Loader Vlocity.
2. OFF – This mode will fire the marker much faster and is not recommend when shooting paintball because you may chop and break a ball. This mode is for the user who may experience a problem with the eyes during a game and want wants to fire the marker faster. The ROF is adjustable and should be setup initially depending on what type of hopper you have. For example, if you have a Vlocity, you can set your eye OFF ROF higher then 10 because the hopper can keep up. If you have a gravity feed hopper, you should setup your eye OFF ROF lower to prevent chops. Eye OFF can also be a training mode, with the right parameters and without shooting paintballs, the marker will works with any fire mode selected giving you a feel for operation. Note: Eyes OFF will be limited to 25 Cycles Per Second (CPS).

Figure 1

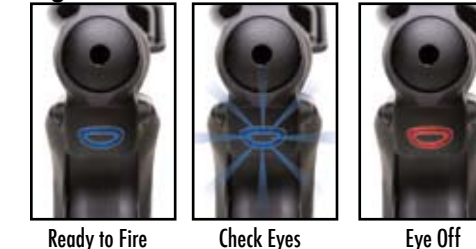

Figure 2

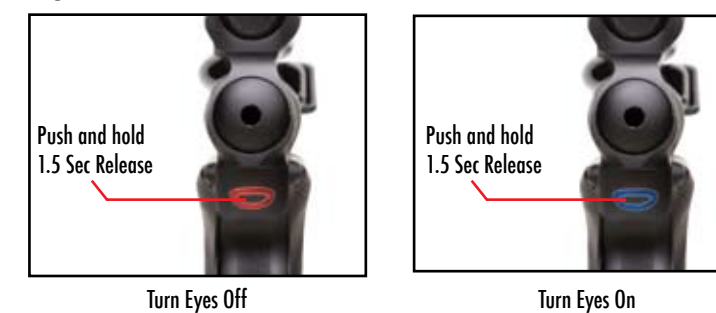
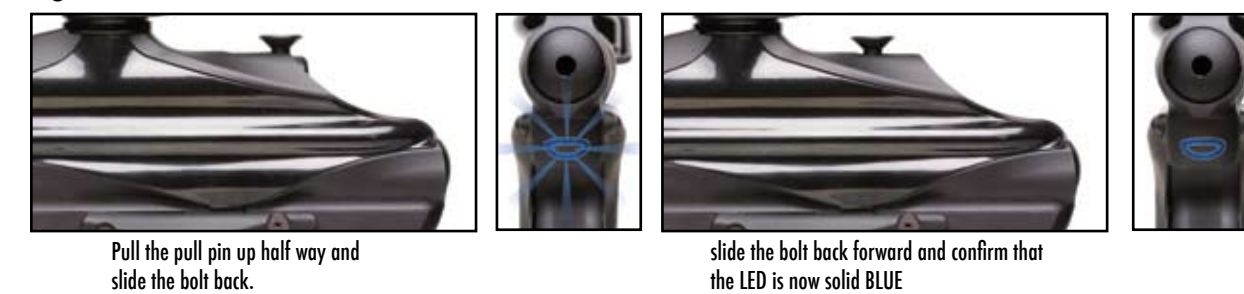

Figure 3



Programming:

To enter programming mode to change settings, press the scroll wheel while the marker is off (figure 4). It will then boot into programming mode and display setting names and their current values. Scrolling up and down with the wheel cycles through the settings. To change one, first select it with the scroll wheel, and then press the wheel in. You can then scroll up and down to change the setting, which will update on the screen as you modify the setting. To save it, press the wheel again, and it will go back to the main programming mode menu where you can scroll to other settings. To exit programming mode hold the power button for 3 seconds, until the OLED screen turns off. Note: If the marker is ON, you will not be able to get into programming mode. Turn the marker OFF first then press the middle button down.

Setting:

DEBOUNCE – The ASR board features an interrupt based debounce algorithm that effectively “scans” the trigger many times per second. It runs this completely independent of code execution on the microcontroller so your trigger pulls are always registered. The debounce setting is in increments of 1 milliseconds. Users should be aware that low debounce settings may cause the marker to read switch bounce as additional pulls, falsely generating shots or near full-automatic fire. The setting ranges from 1 to 50 and is defaulted at 10 ms.

SEAR ON: The amount of time the mechanical solenoid is energized each time the marker is fired. Adjustments can be made in 0.5ms increments with the range of adjustment between 0.5 to 8ms. The default is 4 ms. Too low of a SEAR ON time may lead to inconsistency or marker not firing and double loading. Too high will lower max BPS and drain more power from your battery.

BIP DELAY: BIP (Ball In Place) is the time the marker waits after detecting a ball to start the closing process on the bolt. This time adds a slight delay after the eye has seen a ball and helps prevent chops. Note: If not using force fed loaders, it may be necessary to increase this setting to prevent chopping. A setting of 1ms means almost no loader delay, which is the fastest. The range of adjustment is between 1 and 25ms. The default is 2ms.

AMB (Anti-mechanical bounce): Allows the user to adjust the anti-mechanical bounce feature. Mechanical bounce occurs due to the kick generated during each shot and can cause the marker to “run away” on the first few shots. AMB helps stop markers from going full-auto when the trigger is pulled very slowly. The default is 2 and may be set from 1 to 5 (1 being off). AMB is only used in fire modes 1 and 2 (semi-automatic unlimited and adjustable).

FIRE MODE: The ASR is set up with 12 of the most common fire modes used in tournaments and scenario events. These 12 can be adjusted to meet the standard of different events by adjust and locking ROF. The out of box mode is 100% Ramp with the ROF at infinity. Below is an explanation of each mode:

Mode 1 is normal semi-automatic with an unlimited rate of fire while the eyes are enabled. When the eyes are turned off, the max rate of fire is set to 25 balls per second.

Mode 2 is semi-automatic with an adjustable rate of fire. It limits the maximum balls per second that can be fired. The cap is set by the max rate of fire setting.

Mode 3 is the PSP auto-response fire mode that works as follows:

- The first 3 shots of a string are semi-automatic
- After the 4th shot the marker will fire on the pull and release in auto-response mode
- If the user stops firing for more than 1 second, the 3-shot semi-automatic count starts over

Mode 4 is the PSP 50% ramping fire mode that works as follows:

- The first 3 shots of a string are semi-automatic
- After the 4th shot the marker will ramp, adding 1 additional shot for every 2 pulled by the user, as long as the user pulls the trigger faster than the ramp start setting
- If the user stops firing for more than 1 second, the 3-shot semi-automatic count starts over

Mode 5 is the PSP 100% ramping fire mode that works as follows:

- The first 3 shots of a string are semi-automatic
- After the 4th shot the marker will ramp up to the loader’s maximum speed or the maximum rate of fire, as long as the user pulls the trigger faster than the ramp start setting
- If the user stops firing for more than 1 second, the 3-shot semi-automatic count starts over

Mode 6 is the PSP burst fire mode that works as follows:

- The first 3 shots of a string are semi-automatic
- After the 4th shot the marker will burst fire 3 shots per pull
- If the user stops firing for more than 1 second, the 3-shot semi-automatic count starts over

Mode 7 is the NXL full-automatic fire mode. It functions similarly to the PSP fire modes except, after the 3rd semi-automatic shot, the user may pull and hold the trigger for the marker to fire in full-automatic.

Mode 8 is the normal auto-response fire mode. The marker will fire on each pull and release of the trigger, generating 2 shots per full pull cycle.

Mode 9 is the normal 50% ramping fire mode. The marker will fire in semi-automatic unless the user pulls the trigger faster than the ramp start setting. Once the ramp start setting has been achieved, the marker will 50% ramp, adding 1 additional shot for every 2 trigger pulls.

Mode 10 is the normal 100% ramping fire mode. The marker will fire in semi-automatic unless the user pulls the trigger faster than the ramp start setting. Once the ramp start setting has been achieved, the marker will ramp up to the maximum feed rate of the loader or the maximum rate of fire setting, whichever is lower.

Mode 11 is the normal 3 round burst fire mode. The marker will burst fire 3 times for every pull and release of the trigger.

Mode 12 is the normal full-automatic fire mode. As long as the trigger is depressed the marker will fire in full-automatic.

MAX ROF: The max rate of fire setting applies to the 2nd – 12th fire modes. The max rate of fire is adjustable from 10 to 25 balls per second in 1 balls per second increments, and has an unlimited setting for maxing out the loader system. The default is 15 BPS once the PCBA is reset. Oscillator inconsistencies from chip to chip make it impossible to time perfectly, so the only true way to check rate of fire is to use a Pact Timer or ballistic chronograph. The red radar chronographs commonly found at fields are NOT reliable.

Figure 4



Debounce

↑ DEBOUNCE
↓ 10 MS

Sear On

↑ SEAR ON
↓ 4.5 MS

BIP Delay

↑ BIP DELAY
↓ 2 MS

AMB

↑ AMB
↓ 2

Fire Mode

SEMI AUTO ROF: ∞ ↑ SET FIRE MODE
↓ NXL

↑ SET FIRE MODE
↓ SEMI CAPPED ↑ SET FIRE MODE
↓ AUTO RESPONSE

↑ SET FIRE MODE
↓ PSP RESPONSE ↑ SET FIRE MODE
↓ 50% RAMP

↑ SET FIRE MODE
↓ PSP 50% RAMP ↑ SET FIRE MODE
↓ 100% RAMP

↑ SET FIRE MODE
↓ PSP 100% RAMP ↑ SET FIRE MODE
↓ 3 ROUND BURST

↑ SET FIRE MODE
↓ PSP 3 BURST ↑ SET FIRE MODE
↓ FULL AUTO

CPF (Cycle percentage filter): The cycle percentage filter allows adjustment of the point within the current firing cycle that a new buffered shot is allowed. Almost all electronic paintball markers allow a single shot to be buffered in the event the user is fast enough to release the trigger and pull again during the current firing cycle. The CPF setting is adjustable from 1 to 10. Setting 1 turns the CPF off, allowing buffered shots at any point in the firing cycle. Settings 2 through 10 set the percentage of the firing cycle that must pass before shots may be buffered:

1. CPF turned off
2. 10% of the firing cycle must pass before a buffered shot is allowed
3. 20%
4. 30%
5. 40%
6. 50%
7. 60%
8. 70%
9. 80%
10. 90%

A higher CPF setting results in less unintentional bounce. For instance, it is possible that if your debounce setting is border line, you can fire the marker a few times, then hold it loosely and allow it to brush against your finger, going full-automatic. Since most switch bounce from either a low debounce setting or mechanical bounce occurs almost immediately after the trigger is released, CPF can be very effective in eliminating falsely generated trigger activity.

RAMP START: This setting is only used for the four ramping fire modes (PSP 50% and 100% ramping, and normal 50% and 100% ramping). It sets the minimum pulls per second that must be maintained for the software to add shots or ramp up to the maximum rate of fire setting. The default is 5 pulls per second (PPS) and is adjustable from 4 to 14 PPS.

BREAK OUT: The ASR board includes a special mode that can be applied 3 different ways to each of the 12 fire modes, giving 36 “breakout” style combinations. This mode gives the user full-automatic with an unlimited rate of fire for a single pull, for use at the start of the game. The setting is defaulted OFF. It can be set up with the 1st, 2nd, or 3rd pull to activate. If set to the 1st shot after you turn on the marker, the marker will be full-automatic with an unlimited rate of fire for as long as you hold down the trigger. As soon as you release the trigger, the marker will stop shooting and default back to your selected fire mode. If set to 3rd pull, the mode will be active on the third shot after the marker is turned on. Regardless of the fire mode selected, the shots before the mode will be semi-automatic. Breakout mode can only be used once for each time the marker is turned on.

Note: Break out mode is illegal for use in all tournament series. Worr Game Products takes no responsibility for the user’s choice in using this mode.

OPEN DELAY: Time between sear dropping and the solenoid actuating to open the bolt. The range of adjustment is between 1-20ms. The default is 2 ms. Generally you need this setting to prevent blowback, as you don’t want to open the bolt too soon.

WATCH TIME: It is used during the markers’ eyes ON mode and determines how long the bolt will be held open while waiting for a ball to fall in. Since the ASR is a closed bolt system this setting is necessary for increased battery life. The longer you hold the bolt open waiting for a ball to drop, the more power you use up and intern decrease battery life. The range of adjustment is between 20-400ms and adjustable in 20 ms increments. The default is 200ms. If a ball falls in before the end of the time it will automatically close, maximizing rate of fire. Generally with a good loader the bolt will only be back for 20 ms or so. We recommend upping this time to prevent ball breaks if you are using a gravity feed or slower hopper. This higher time would also help at the end of a hopper load.

CLOSE TIME: time after the eyes have seen a ball drop into the breech that we allow for the bolt to close completely. We don’t want to start firing the loaded ball before the bolt closes or else the velocity will be low and we’ll have tons of blow back up the feed tube. The range of adjustment is between 1-20ms. Default is 14 ms. Depending on the conditions this time generally can be brought down increasing BPS.

EYE OFF ROF: The user also has the option to adjust the eyes OFF ROF. This will allow the user to slow down the marker to match the speed of their hopper. The range of adjustment is between 10-25 BPS. The default is 15 BPS. Note: It is not recommended to shoot the marker with the eyes OFF since chopping a ball(s) could result. For best results, always confirm eyes are fully functionally and shoot marker with the eyes ON.

RESET – To reset all settings to factory defaults, press middle button down. The program will ask if you really want to reset? If you do, scroll up until you see “YES”, press the middle button down to confirm and the marker will reset to the factory settings.

Programming Examples:

As an example: Marker OFF, press middle of scroll wheel. OLED screen displays “Programming Mode” for a moment. OLED screen displays first setting, “DEBOUNCE” and on the line below, the current value, “10ms”.

Push the scroll wheel down and the OLED screen will show the “SEAR ON” setting. Now press the wheel in to adjust the SEAR ON time. The OLED will display “SET SEAR ON”, which is the time the board tells the mechanical solenoid to energize allowing the sear to trip the lug and send the hammer forward and firing the marker. Scroll the wheel up to adjust it to 4.5ms and press the wheel in to select it. This will now take you back to the main menu.

Now scroll the wheel up until you see the “CLOSE TIME” setting. Press the middle wheel in to adjust the close time. The OLED will display “SET CLOSE TIME”. Lower the setting by pushing the scroll wheel down. Each time you scroll the wheel down, the time will decrease by 1 ms. Scroll down 2 times so it displays “12 ms” as the new setting.

Save the setting by pressing the middle of the scroll wheel. This will also take you back out to the main menu. Exit programming mode by holding the rear power button until the OLED turns OFF.

CPF

↑ SET CPF
↓ 2

Ramp Start

↑ RAMP START
↓ 5 PPS

Break Out

↑ BREAKOUT
↓ OFF

Open Delay

↑ OPEN DELAY
↓ 12 MS

Watch Time

↑ WATCH TIME
↓ 160 MS

Close Time

↑ CLOSE TIME
↓ 14 MS

Eyes Off Rate of ROF

↑ EYES OFF ROF
↓ 15 BPS

Reset

↑ RESET
↓ NO

Example Setting Profiles:

1. Tournament legal semi-automatic (NPPL)
 - a. Fire mode 1 or 2 (semi-auto unlimited or capped)
 - b. Debounce 5-20
 - c. AMB 2
 - d. CPF 2-5
 - e. Watch time 200ms for Vlocity or 400ms for gravity feed
2. PSP X-Ball, CFOA
 - a. Fire mode 3, 4, 5, or 6
 - b. Max rate of fire set to 15BPS, depending on Pact Timer readings
 - c. Debounce 5-20
 - d. Ramp start 5 or higher if using PSP 50% or 100% ramping
 - e. Watch time 200ms for Vlocity or 400ms for gravity feed
3. Millennium
 - a. Fire mode 4, 5, 9, or 10 (PSP or normal ramping modes)
 - b. Max rate of fire set to 15 BPS, depending on Pact Timer readings
 - c. Debounce 5-20
 - d. Ramp start 8 or higher
 - e. Watch time 200ms for Vlocity or 400ms for gravity feed
4. NXL
 - a. Fire mode 7 (NXL full-automatic).
 - b. Max rate of fire set to 15 BPS, depending on Pact Timer readings
 - c. Debounce 5-20
 - d. Watch time 200ms for Vlocity or 400ms for gravity feed
5. Speed (absolute fastest/bounciest)
 - a. Any fire mode
 - b. Max rate of fire set to unlimited
 - c. Debounce 1
 - d. AMB 1 if using semi-automatic
 - e. CPF 1
 - f. Ramp start 4 if using any ramping modes

Additional Features

A tip for setting the debounce, AMB, and CPF - This only applies to semi-automatic fire modes (modes 1 and 2) since AMB is disabled in the PSP fire modes or NXL mode.

Debounce, AMB, CPF setup steps, while using paint and air:

1. Turn AMB and CPF off (set both to 1).
2. Starting at debounce 1-3, raise the debounce setting a notch at a time until excessive trigger bounce goes away. The goal is to have one pull, one shot, regardless of rate of fire. Do NOT slow pull test for bounce during this phase. Instead, pull the trigger rapidly or walk it, listening for double or triple fires.
3. When it appears that it is only one shot, one pull for solid trigger pulls, try the slow pull test. Holding the marker steady, slowly pull the trigger and see if multiple shots can be generated from the single pull.
4. Increase the CPF setting a notch at a time until the slow pull bounce starts to disappear. An additional test is to fire a few rounds quickly, then hold the trigger right on the activation point to see if the marker will run away.
5. If you reach setting 10 with CPF and the marker can still be slow pulled to fire full-automatic, your debounce setting is probably too low. Go back to step 2.
6. AMB should not be set above 3, if possible, since it is not as transparent to the user as CPF. Even a CPF setting of 10 will not be noticed by the user.

In order to maximize rate of fire you need to run the sear ON, loader delay, open delay, and close time as low as possible, without affecting velocity or blowback. This is only intended to see how fast you can set up the marker to shoot. We recommend setting the marker to be matched and balanced with your loader. Set up should be made so that your marker will be smooth and consistent. For example at 15 BPS, your marker should fire with a very good stream using a Vlocity loader.

operation and maintenance

Operation

Velocity adjustment: Most paintball fields have a limit to ball velocity and will provide a chronograph for the user to check. There are many conditions that will affect velocity. There are 2 ways to adjust the velocity of the ASR and other traditional Autococker style markers. One is adjustment of the rear IVG. Use a 3/16" Allen key to turn the IVG in to increase the velocity and out to decrease (Figure 5). The other way velocity can be adjusted is by adjusting the HP regulator (Figure 7). Going up or down in pressure can either increase or decrease your velocity. Make small adjustments and check your velocity with a couple of shots.

Paintball to barrel fit is important with Autockers. Since the ASR is a closed bolt system, once the ball is fully breeched, the bolt will close pushing the ball forward waiting to be fired. If the ball is too small and does not fit the barrel correctly, there is a potential for the ball to roll part way down the barrel when the marker is pointed down. The first shot may be at a low velocity, while the next one is normal. Point the gun down, and shake the marker. If the ball rolls out of the barrel, the paint is too small for that barrel. If the paint is too big for the barrel, you can get blow back, and barrel breaks. To check for fit, take the barrel off, and put a ball in the end. If you can blow the ball out of the barrel with a light puff of air, it's fine. If it rolls then it's too small. If it gets stuck then the paint is too big. The ASR stock barrel size is .689". WGP offers barrel kit for adjustment with varying paint sizes. The ASR 2 piece barrel is interchangeable with other WGP Kaner kits.

Newer hopper technology now force paintballs down into the breech and actually apply pressure on the ball. The ASR been designed with new dual ball detents nubs which should eliminate double feeding. When attaching a hopper, use a 5/32" Allen key to loosen the top rotating clamp (Figure 6). Press the hopper all the way down and tighten screw (Figure 6.2). There are 2 rotating points on the new rotating feedneck. Some users prefer having the clamp at the front depending on their hopper. Set the feedneck up how you prefer it and tighten both screws before a game. Note: WGP recommends the use of a higher end hopper, example the View Loader Vlocity.

ASR High Pressure (HP) regulator has been designed for high flow and regulated pressure consistency. It has been set up from the factory with the most consistent setting for the highest performance for most users. The regulator is designed to eliminate creep and spiking. There are many variables, depending on weather, temperature, paint, hopper, and playing conditions, the user may need to make an adjustment to the regulator pressure. Sweet spotting the regulator will give the individual user optimal performance. The regulator maintains a constant pressure thus firing the ball more consistently and accurately. Velocity could still fluctuate due to variations in paintballs but should still be very consistent.

To turn the pressure up, use a 1/4" Allen key and turn the Regulator Adjustment Screw out counterclockwise. To decrease pressure, turn the Regulator Adjustment Screw in clockwise (Figure 7).

To set the regulator for the most consistent, and efficient pressure, first set the IVG adjuster on you gun to the mid point. It doesn't have to be exact just close. This is to ensure that if you go out to a field and shooting high that you have some room to back it out. Now, turn the regulator down to the point where the gun fires consistently and re-cocks. You will probably be shooting under 200 fps. Now slowly turn the regulator up, and chrono after every adjustment. The FPS will go up as the pressure from the regulator goes up. When the velocity stops going up, that's where you will get the most shots per tank. If you go up too far past this point, you will actually see the velocity begin to drop. The higher pressure can also be harder on your paint causing more breaks. It's not the quietest pressure, but it's the most efficient.

Now that it's set up at the most efficient spot you now have to find the "sweet spot" for the marker. It is typically on most markers just below the setting that's the most efficient. All you have to do is play with the pressure a little. Lower the pressure a little and then take a couple of shots over the chronograph. Bring it up a touch, and do it again. It will take a couple of iterations and will require patience. Note: Use good high quality paint. Try to use paint that you plan on using at the field to be consistent.

Note: Large adjustments to the HP regulator could affect the Low Pressure Regulator (LPR). User should also check LPR settings, see next section.

The Low Pressure Regulator is located on the front of the new manifold. The regulator controls the amount of pressure applied to the pneumatic valve and ram. If there is not enough pressure to the ram, the marker may re-cock but not fully and completely. If too high, you could blow out o-rings and gaskets. To adjust the regulator pressure, use a 3/16" Allen key. Start by turning the adjustment screw out counterclockwise (Figure 8). With the marker ON and pressurized, turn the eyes OFF and fire the marker. The bolt should start to move back and re-cock the system. Turn the screw in clockwise to increase the pressure and apply more force to re-cock. Fire the marker to confirm bolt moves all the way back and re-cock the system. The right pressure re-cocks the system and has the right feel. If the pressure is too high, the system will re-cock but do it more violently. Safety Note: Always practice safe paintball marker handling and procedures. Confirm Barrel sock is attached and secured correctly.

Lug adjustment: The lug is what holds the hammer back. Once the solenoid is energized, the sear will trip the hammer sending it forward and firing the marker. The lug position determines how effectively the hammer is tripped and is very important with Autockers. If the lug is too low, more time may be required on your SEAR ON time to release the hammer and may not even trip. If the lug is too high, the hammer may not catch the sear and be held back. Lug adjustment is also considered part of mechanical timing and will affect performance. Mechanical adjustments with SEAR ON time adjustments will yield the best marker performance. Lug locking and adjustment on the ASR is simple and will require a 1/8" Allen key. Note: Make sure mark is degassed properly before making any modifications to the lug.

First start by loosening the rear lug locking set screw (Figure 9). Remove the bolt. Now turn the lug up or down by inserting you 1/8" Allen key from the top of the marker into the lug (Figure 9.2). To check position, insert your bolt and cock the marker back manually. Turn the marker ON, and fire the marker. If the sear does not release the hammer, turn the lug out. If cocking the hammer back and the lug does not catch the sear, turn the lug in slowly and re-cock to check if it catches. Once in the correct position, lock the lug in. This process will require patience since many iterations maybe required. Safety Note: Always practice safe paintball marker handling and procedures. Confirm Barrel sock is attached and secured correctly.

Figure 5



Figure 6

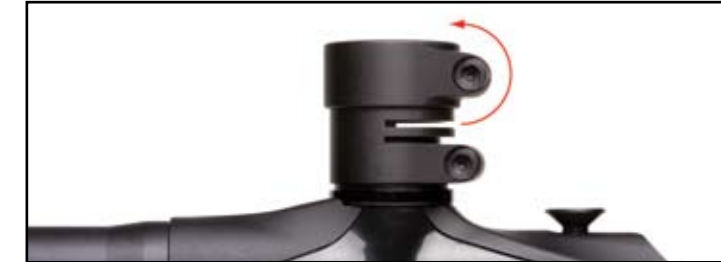

Figure 6.2



Figure 7



Figure 8



Figure 9



Figure 9.2



maintenance

Your Autococker® SR Marker was thoroughly inspected and test-fired at the factory and should only require verifying the velocity adjustment with a chronograph before use. After extended use and under varying conditions, your marker may require some adjustment. When performing any adjustments on the marker, check for paintballs in the marker, breach and loader. Again, if you are not certain of your skills, have any adjustments performed by a qualified technician. Any damage caused by improper adjustment is not covered under warranty.

It isn't necessary to completely disassemble your marker to clean it. WGP recommends the following cleaning be done after each day of play. Note: Ensure all paintballs are out of the marker, air source is removed and marker is degassed, and marker is OFF. Remove the barrel sock and then remove the barrel. Lightly spray marker down with a 50-50 mix of rubbing alcohol and water and then wipe down. Wipe down the marker with a clean cloth, or blow off the marker with compressed air (NOT CO2). Remove bolt and lubricate bolt O-rings with petroleum jelly or lithium grease, then reinstall. WGP recommends that after every 4-5 days of play, place 3-4 drops of 3 in 1 or other paintball marker specific oil in the air receiver and fire the marker 10-15 times without the barrel. This will distribute the oil throughout the marker and lubricate the internals. Remove the battery and store the marker in a cool place.

Factory approved lubricants:

- Petroleum Jelly
- Lithium Grease
- 3 in 1 Oil

The ASR is made to withstand paintball shots from 10 feet away. Paint may sometimes enter the marker. If excess paint is present and can not be cleaned using a clean cloth, disassembly may be required. Before any disassembly, confirm marker is OFF and degassed properly.

Macro Line Quick Disconnect hose (Figure 10): The ASR is equipped with a Macro Line Quick Disconnect hose. (see diagram) This hose can be easily disconnected when not under pressure (when no cylinder is attached) Simply push the macro line ring towards the fitting and pull on the hose at the same time. This feature is designed for quick and easy maintenance and upgradeability. Check the hose for any visible damage or cuts. If damaged, replace immediately. Reassembly is easy, press the hose all the way into the fitting. Note: If the user is not familiar with a Macro Line, WGP does not recommend removal. Take the marker into an approved service center for maintenance.

Eye cleaning and ball detent repair: The ASR has been designed with new light weight body covers to protect the marker's vital components from paint and debris. These covers help retain the break beam eyes and ball detents. They protect the wires and enclose the pump rod and side cock block. If paint or debris get inside, removal and cleaning may be required. Start by removing the left and right side grip panels (Figure 11). Remove the barrel and bolt. Use a 5/32" Allen key to loosen the bottom feed neck screw. Pull the feed neck up and off of the feed port adaptor. Use your 5/32" Allen key to remove the feed port adaptor by putting it thru the hole in the adaptor and turning it out counterclockwise (Figure 11.2). Now pull the Upper Panel Retaining Ring up and off. Use a 5/64" Allen key to remove the front panel retaining screw (Figure 11.3). Remove the rear retaining screw. Carefully remove both left and right side panels (Figure 11.4). Clean the eyes and examine the ball detents nubs (Figure 11.5). Use alcohol and a q-tip. Be very careful since the eyes are delicate. Reassemble the eyes into position and use the provided round tape to retain and aid in reassembly. When reassembling, make sure wires are not kinked or in a position that they can be cut.

Frame (Figure 12): The ASR frame has been designed to be trouble free but still may require some minor maintenance. The new PCBA cover helps protect the PCBA and reduce paint contamination. It is still possible to have paint or debris get into the frame and PCBA section. To disassemble and clean, first start by removing the left and right side panels. Unplug the break beam eye and pneumatic valve connectors from the right side of the frame (Figure 12.2). Disconnect macroline hose (see instructions above). Use a 1/8" Allen key to remove the screws (Figure 12.4). From above, clean any debris from the sear and solenoid section.

If sear removal is required, use a 1/16" Allen key to loosen locking set screw (Figure 13). Carefully push the sear pin out from right to left (Figure 13.2). Remove the sear return spring and clean the area with a q-tip. Clean the sear and carefully reassemble. Tighten sear set screw and lube the sear with petroleum jelly. Note: Make sure sear return spring is reassembled, if not marker will not operate properly.

PCBA removal and cleaning: Note: This should not be done unless the user is very familiar with electronic care. Be very carefully with the PCBA, static can damage the sensitive electronics. If excess debris is inside the PCBA area and needs cleaning, use a 1/16" Allen key to remove the 2 screws that retain the PCBA cover on the right side of the frame and remove the top screw on the left side (Figure 12). Carefully remove the PCBA cover. Use a 5/64" Allen key to remove the PCBA screw and carefully pull the PCBA out (Figure 12.2). Carefully unplug the connectors to the rear LED, microswitch, and solenoid (Figure 12.3). Clean area with alcohol and reassemble.

Trigger removal: Use a 1/16" Allen key to loosen the trigger set screw (Figure 14). Slide the trigger pin out and remove the trigger (Figure 14.2). Clean the trigger and trigger pin hole on the frame. Reassemble, confirm that the pin is centered and lock the set screw down. Lubricate all moving parts with Vaseline, and reassemble.

Hammer Removal and installation: Debris and dirt can enter the lower tube and contaminate the hammer and slow down the movement. This will affect your function and velocity. The hammer should float and move smoothly even with out the spring pushing it. To check this, remove the rear IVG and spring. Note: Confirm marker is degassed properly and always practice safe paintball marker handling and procedures. Confirm Barrel sock is attached and secured correctly. Cock the hammer back and point the marker down. Now turn the marker on and fire the marker releasing the hammer. If the hammer moves freely and strikes the valve, then disassembly is not required. If the movement is slow and obstructed by excess debris and dirt, you will need to remove the hammer and clean the inside of the lower tube and hammer. Remove the bolt and use a 1/8" Allen key and loosen the lug locking screw at the rear of the hammer (Figure 15). The hammer will be held in by the lug and will not fall out. Now point the marker up and use your 1/8" Allen key to unscrew the lug out turning it counterclockwise (Figure 15.2). Note: Keep track of how far you

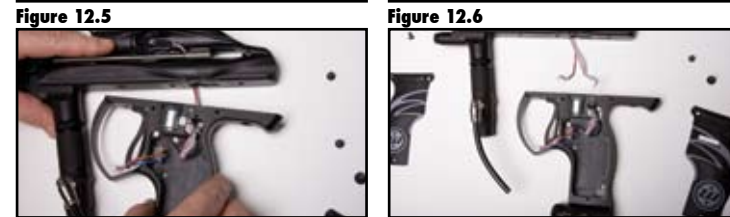
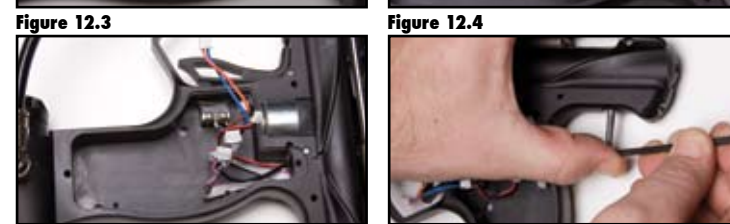
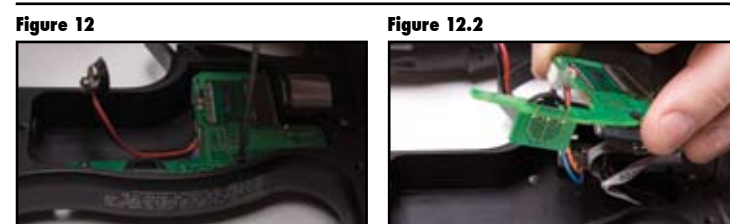
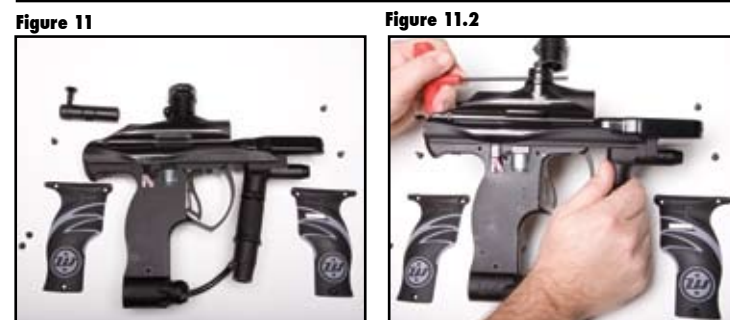
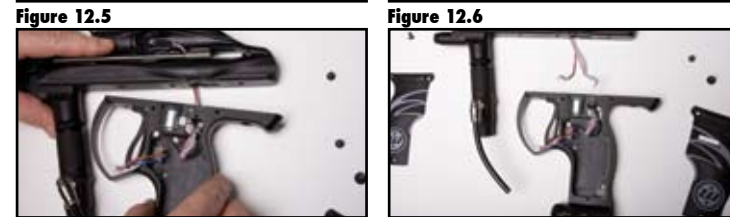
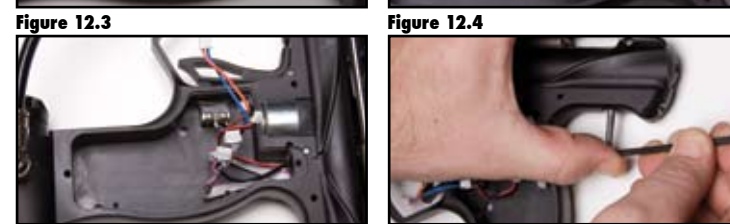
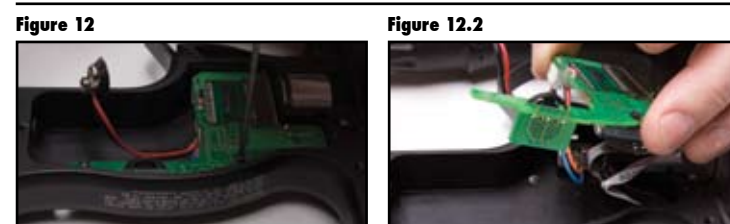
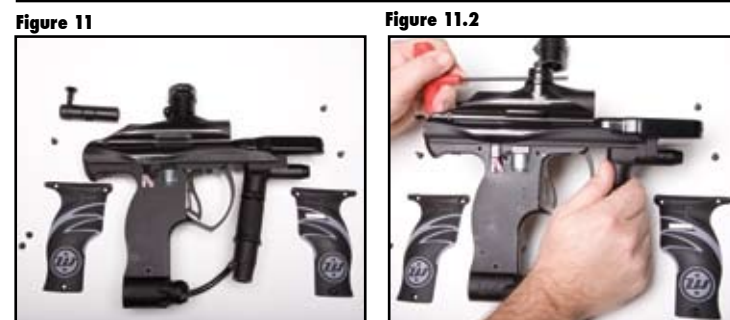

turn the lug out because you will have to reset the lug when reassembling. Once the lug moves out far enough, the hammer will be able to be removed. Slide the hammer out of the rear (Figure 15.3). Clean the hammer and lower tube. Lightly lube the hammer with oil or petroleum jelly. Reassemble the hammer and adjust you lug to the right position (see Lug adjustment process).

The front block manifold of the ASR has been completely redesigned. All air passages are internally ported to increase efficiency and reduce maintenance while increasing ROF. The manifold is gasket sealed with no hoses. The pneumatic valve has been brought closer to the ram with almost a direct connect for air flow making the ram faster. The new MP5 ram has been design with 2 integrated turbo relief valves (TRV's) that vents air directly out into atmosphere. Minor maintenance may be required.

The ram is a two-sided piston and is powered by air. The ram pushes the pump rod back and forth cocking the marker and loading paintballs. Keeping the ram lubed is very important and will ensure long marker life. Use some petroleum jelly and apply some to the pump rod where the ram end cap is (Figure 16). Manually cycle the pump rod to apply lubrication onto the end cap o-ring. This will increase the life of the o-ring decreasing chances of air leaks. Putting oil in the ASA and cycling the marker will also internally lube the ram.

Front manifold assembly repair should be done by qualified technicians only.

Pneumatic solenoid removal and adjustment should only be done if air is leaking from the gasket. First remove the solenoid cover on the right side by unscrewing the screw with a 1/16" Allen key. (Figure 17) Remove cover by pulling out. With a small flat head screw driver, unscrew 2 screws (Figure 17.2) and carefully inspect bottom gasket for cuts (Figure 17.3). Clean surface on manifold and carefully reassemble.

Ram removal and cleaning should not be done if user is unfamiliar with marker assembly. Advanced maintenance is required here and should be done by qualified technician. Start by first removing the pneumatic valve (see above). Remove the left side panel and bolt. Use a 1/16" Allen key and remove the 3 screws (Figure 18). Pull ram away from body (Figure 18.2). Check ram housing gasket for cuts or tears. If damaged, replace. Clean ram housing surface and reassemble. Reassemble and check for leaks. To remove and replace ram shaft o-ring, remove ram housing. Unscrew ram end cap with 1/4" wrench (Figure 18.3). Pull ram end cap with pump rod and shaft out carefully (Figure 18.4). Clean internal ram housing and shaft. Replace the ram shaft o-ring and re-lube assembly. Carefully reassemble and use loctite on the ram end cap when reinstalling. Allow time to dry before use.

Side Cock Block adjustment: The ASR has been factory set to the best position and WGP does not recommend making adjustments unless the user is familiar with autococker function and slide position. If adjustment is required, first start by removing the left side receiver panel. This will expose the slide. First check current position, in the forward and rear position, there should be a gap between the front and back of the slide with the receiver slide cut out area. This can be done manually. If the slide is hitting the receiver in the front or back, you could break the pump rod because excess impact forces will translate from the slide to the pump rod. First loosen the slide locking set screw with a 3/32" Allen key (Figure 19). Now rotate the pump rod to adjust the position of the slide (Figure 19.2). Check position manually by cocking the slide all the way back and forward. Once in the right position, use "Loctite" on the pump rod, set screw and tighten. Allow time for Loctite to dry before use.

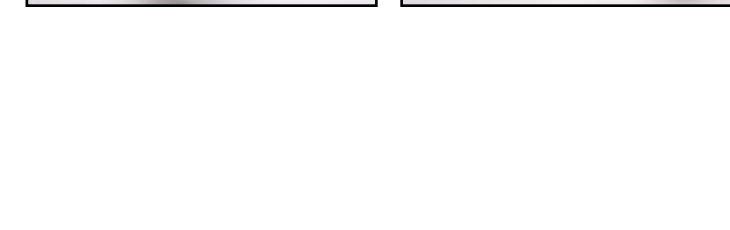
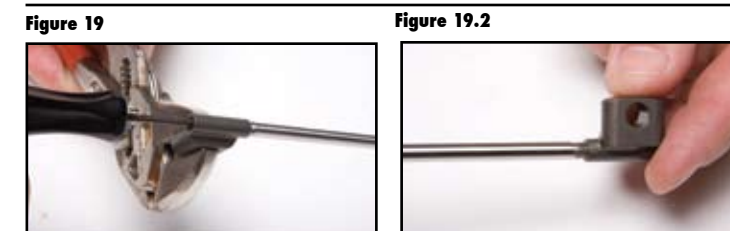
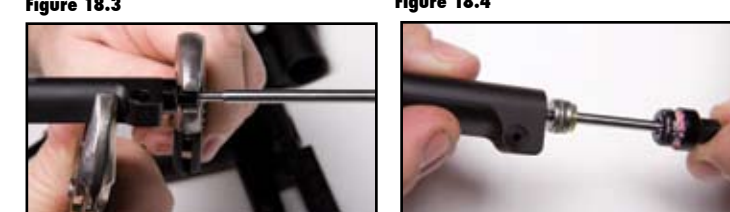
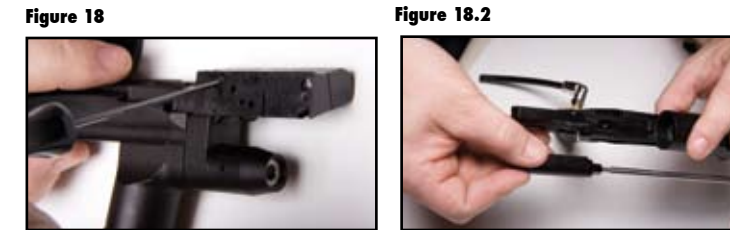
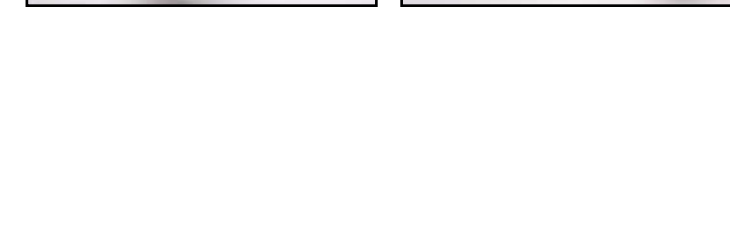
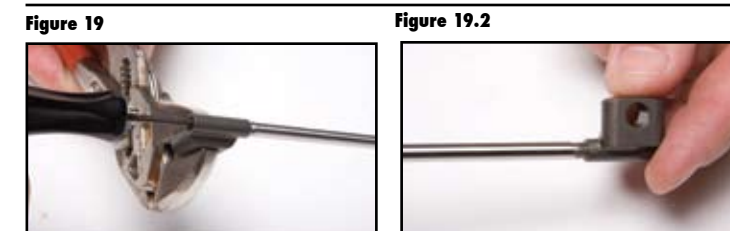
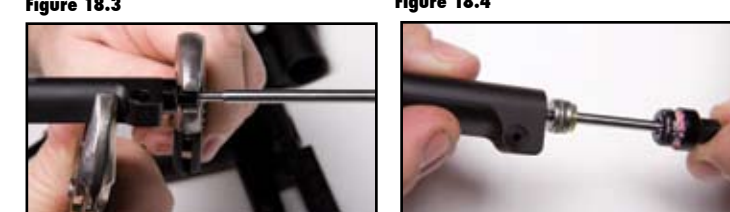
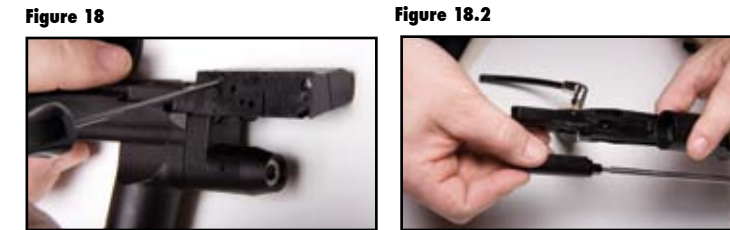
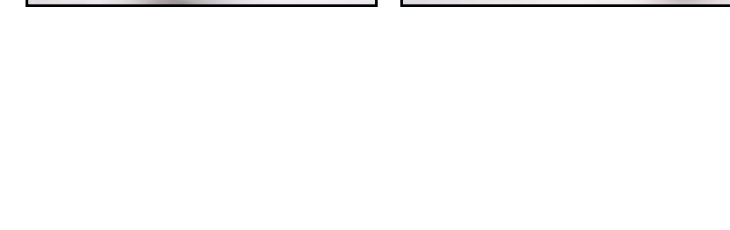
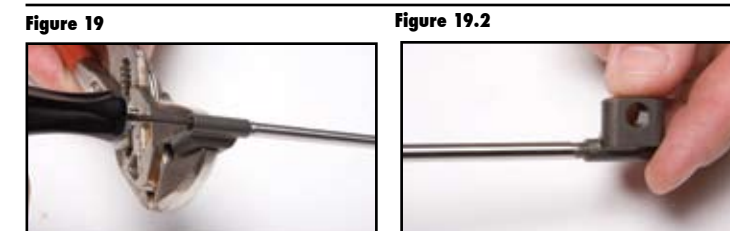
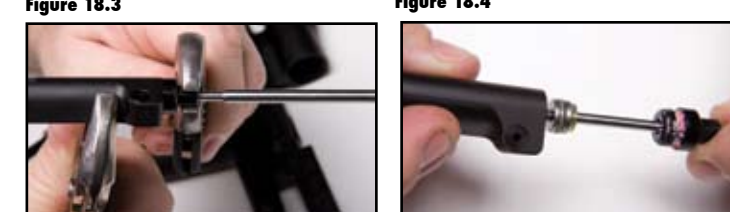
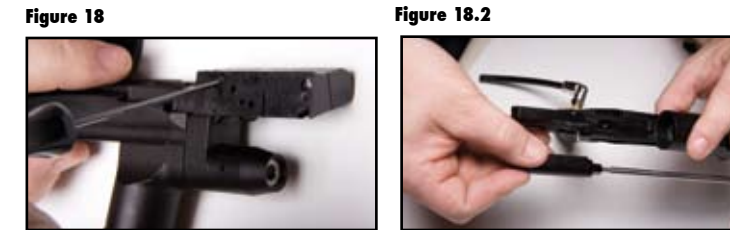
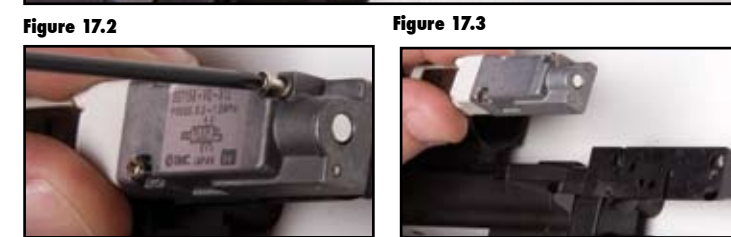
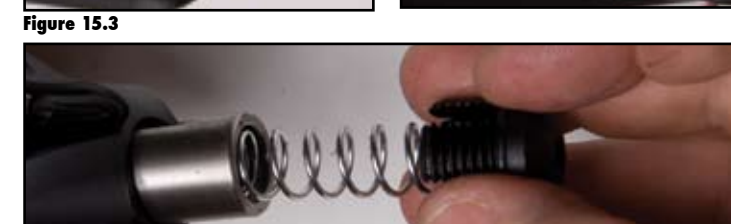
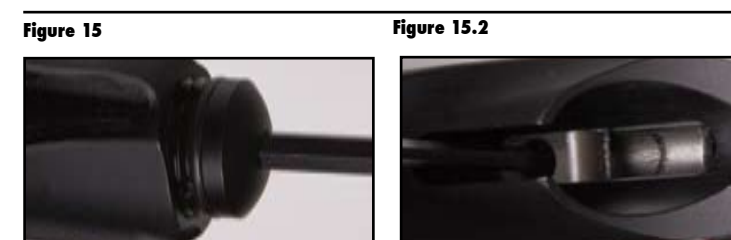
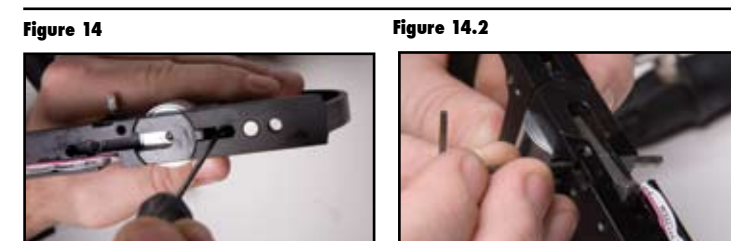
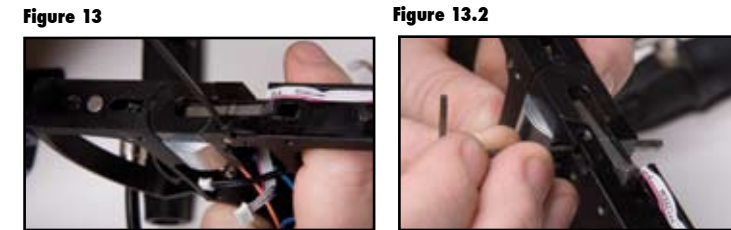
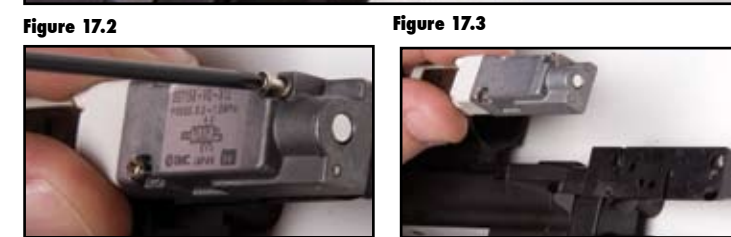
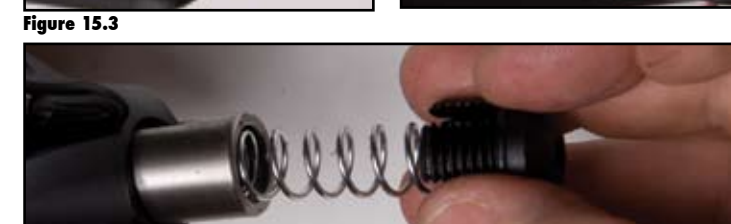
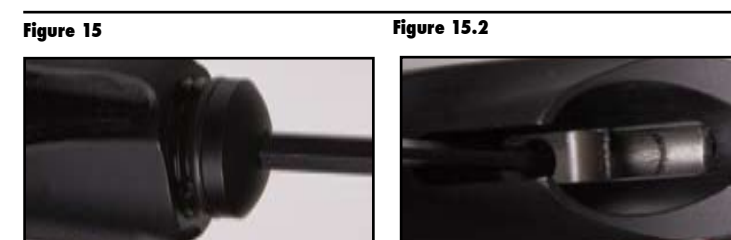
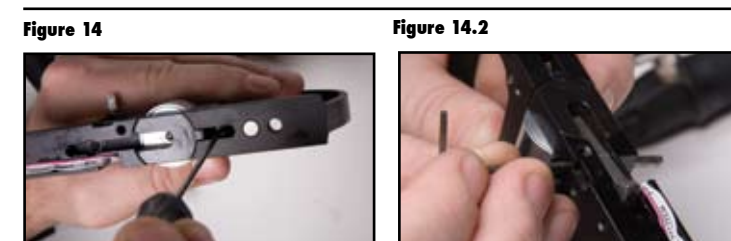
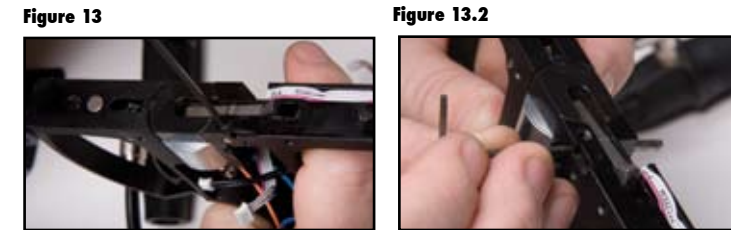

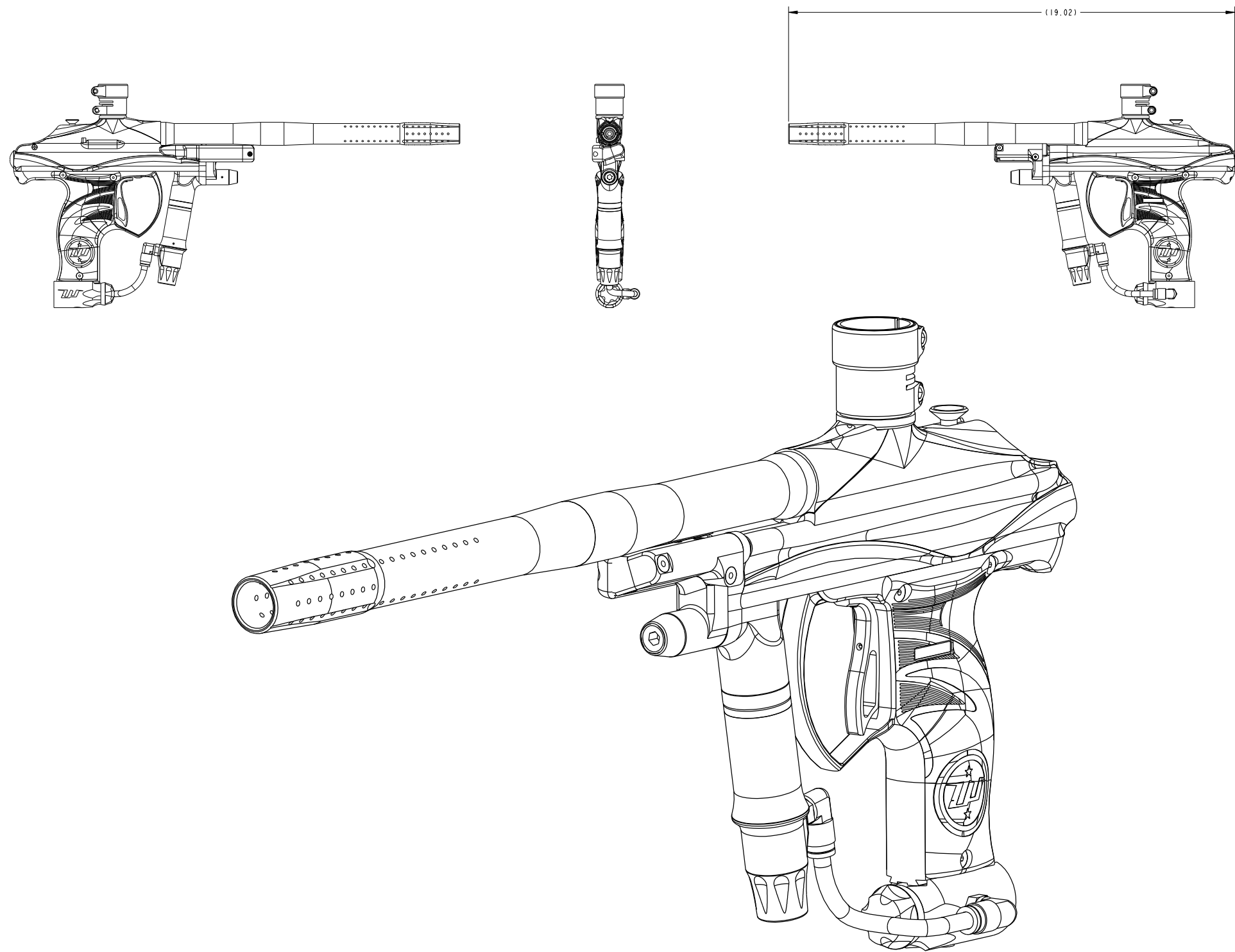

FIND NO.	PART DESCRIPTION
1	3-48 UNC 3A 1/4" SCREW
2	#6-32 SCREW L1/4
3	1/4" MACROLINE
4	ASA 10 DEGREE
5	BALL DETENT
6	BARREL PRIMARY .689 BORE
7	BARREL TIP 14 "
8	BOLT ASSY
9	BOTTOM PLUG - 0475/0476/0477
10	BREAK BEAM EYES
11	CLAMP FEED NECK BASE
12	CLAMP FEED NECK TOP
13	COVER SMC
14	COVER-RECEIVER L 1147
15	COVER-RECEIVER R 1147
16	CUP SEAL
17	EYE STICKER
18	FEED PORT ADAPTER
19	FRAME SCREW 10-32 X 1/2
20	FRONT RECEIVER CAP BOLT
21	HAMMER ASSY
22	INLINE REGULATOR ASSY
23	INTERNAL VELOCITY GOVERNOR (IVG)
24	MANIFOLD ASSY
25	MANIFOLD BOLT
26	O-RING
27	O-RING - PARKER #2-015
28	O-RING 2-016
29	O-RING, INLINE/LOW PRESSURE REGULATOR -WGP
30	ORING 2-012 ID 3/8
31	PCBA COVER-SCREW
32	PULL PIN
33	RECEIVER MIDRANGE
34	RETAINING RING UPPER PANNEL
35	SCREW #12-24 X 7/16
36	SCREW AIR RECEIVER
37	SCREW CSK 10-32 L 1/2 W1/8" HEX SOCKET
38	SET SCREW 10-32 X 5/16
39	SIDE COCK BLOCK
40	SPRING MAIN A 78
41	SPRING SOFT LPR A-35
42	SPRING VALVES A 63
43	TRIGGER FRAME ASSY
44	VALVE ASSY
45	VALVE STEM, MARKER A -WGP

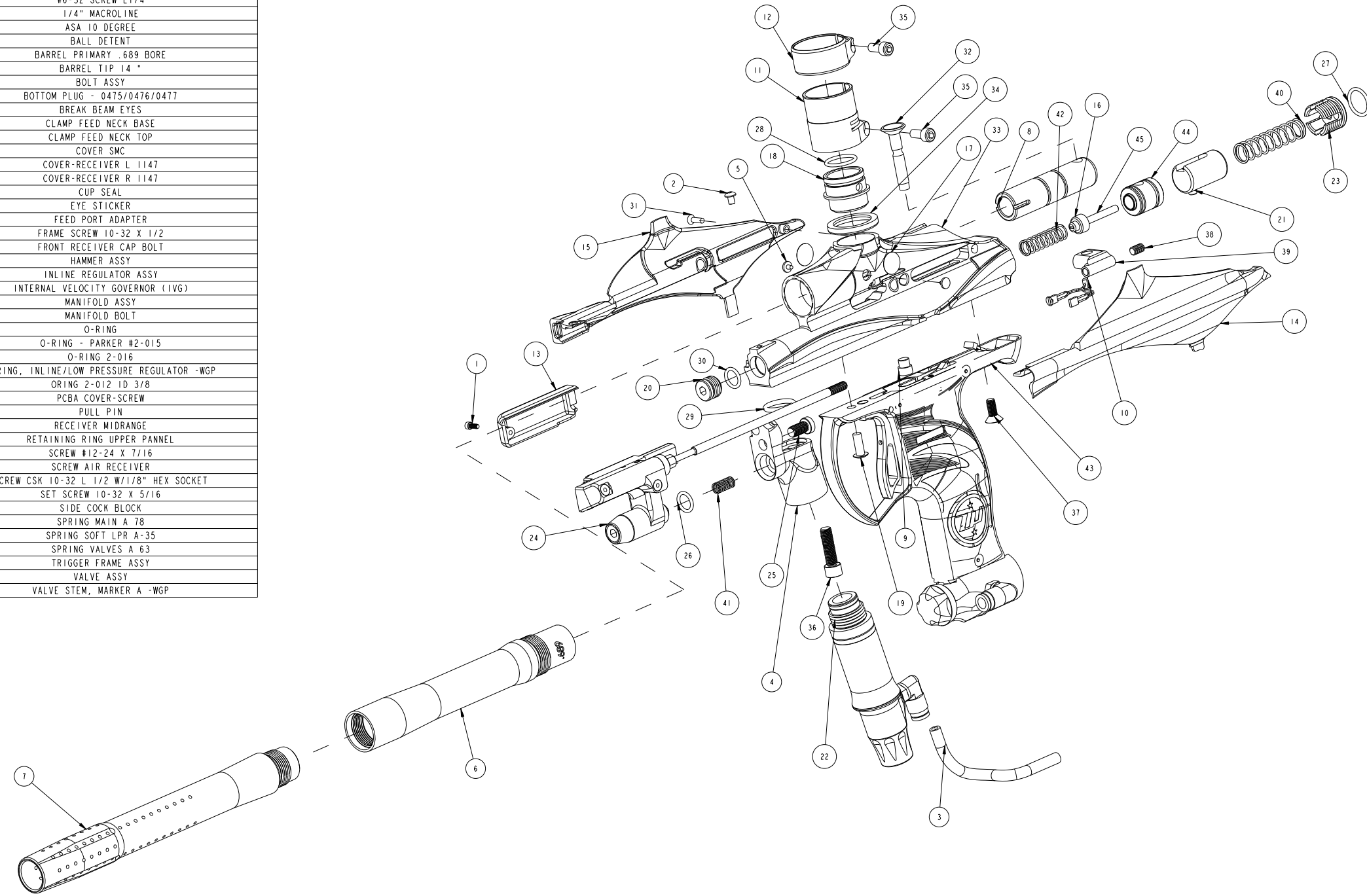

FIND NO.	PART DESCRIPTION
1	SET SCREW 6-32 X 1/8 MULTI USE
2	SEAR PIN
3	SET SCREW 10-32 X 5/16
4	GRIP SCREW 6-32 X 3/8
5	SOLENOID DC LINEAR
6	SPRING-SEAR ELECTRONIC A-45
7	WORR E-SEAR
8	WORR TRIGGER MAGNET
9	SCREW 4-40
10	TRIGGERFRAME
11	PCBA COVER
12	DC SOLENOID RETAINER
13	PCBA-ON/OFF
14	BUTTON-ON/OFF
15	BUTTON-RING
16	PANEL-GRIP L BOTTOM
17	PANEL-GRIP R
18	PCBA-MAIN
19	PCBA BOARD-SCREW-#2-56 X 3/16"
20	COVER-SCREW #4-40
21	RIGHT GRIP PANEL BOTTOM
22	MICROSWITCH SCREW
23	MICROSWITCH WITH CONNECTOR
24	PIN OD 3.18 L 18MM
25	TRIGGER ASSY
26	BOTTOMLINE ASSY

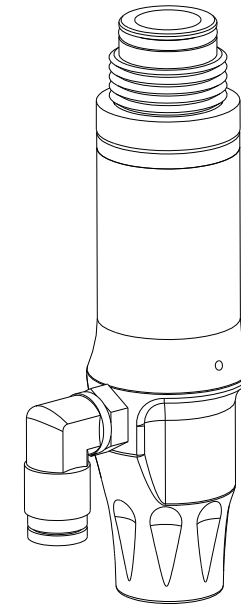
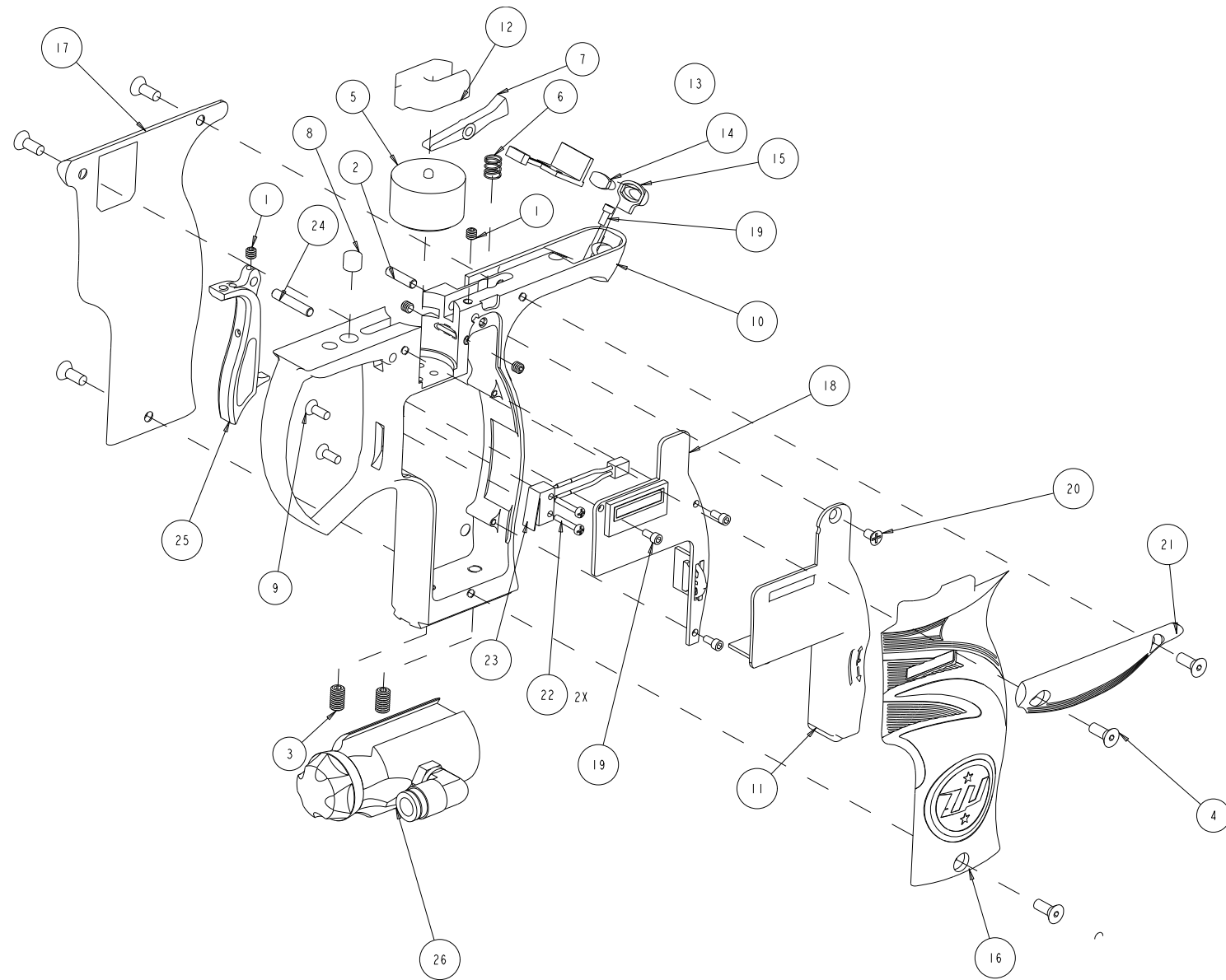

FIND NO.	PART DESCRIPTION
1	O-RING, INLINE/LOW PRESSURE REGULATOR -WGP
2	PISTON O-RING RETAINER
3	O-RING, REGULATOR -WGP
4	O-RING, INLINE/LOW PRESSURE REGULATOR -WGP
5	PISTON INLINE REG -WGP
6	BELLEVILLE SPRING WASHER -WGP
7	SPRING, REG -WGP
8	REG RETAINER CLIP
9	RETAINER O-RING / SPRING GUIDE -WGP
10	O-RING, LOW PRESSURE PISTON STEM -WGP
11	REG SCREW ADJUSTER
12	ERGO REGULATOR END CAP
13	REGULATOR ADJUSTER RING
14	SEAL-'05 ADJUSTER
15	ADJUSTER VENT PISTON
16	ADJUSTER PISTON
17	SPRING -ADJUSTER PISTON
18	INLINE REGULATOR BODY
19	FITTING-MACROLINE 90 DEG

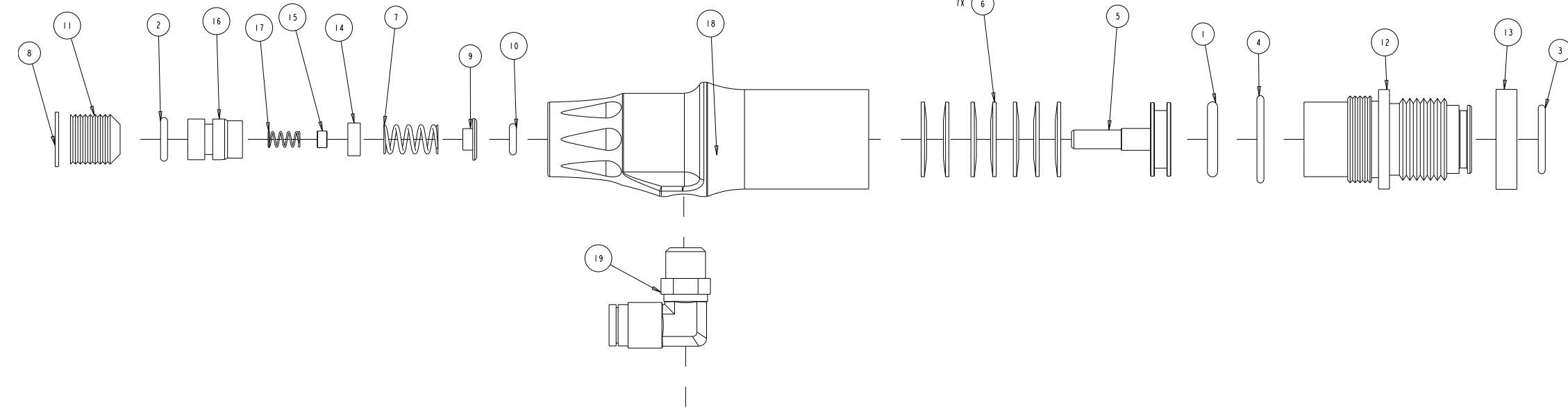

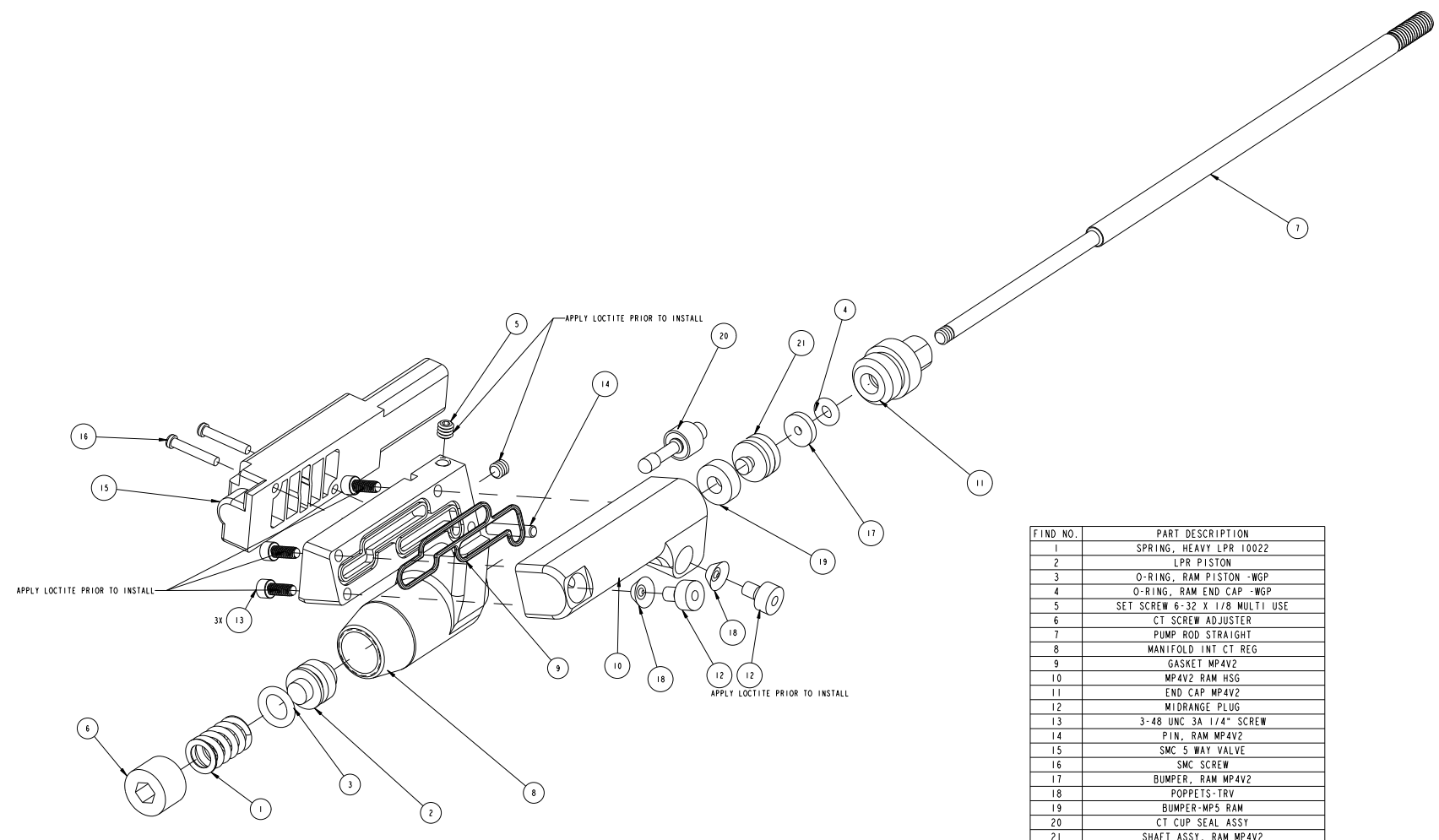

FIND NO.	PART DESCRIPTION
1	SPRING, HEAVY LPR 10022
2	LPR PISTON
3	O-RING, RAM PISTON -WGP
4	O-RING, RAM END CAP -WGP
5	SET SCREW 6-32 X 1/8 MULTI USE
6	CT SCREW ADJUSTER
7	PUMP ROD STRAIGHT
8	MANIFOLD INT CT REG
9	GASKET MP4V2
10	MP4V2 RAM HSG
11	END CAP MP4V2
12	MIDRANGE PLUG
13	3-48 UNC 3A 1/4" SCREW
14	PIN, RAM MP4V2
15	SMC 5 WAY VALVE
16	SMC SCREW
17	BUMPER, RAM MP4V2
18	POPPETS-TRV
19	BUMPER-MPS RAM
20	CT CUP SEAL ASSY
21	SHAFT ASSY, RAM MP4V2

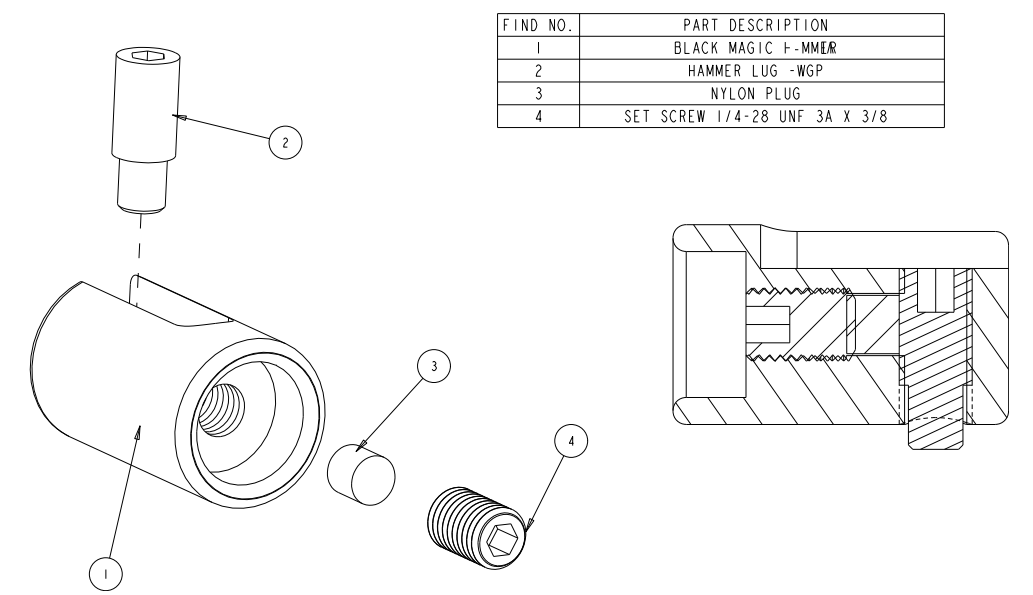

FIND NO.	PART DESCRIPTION
1	BLACK MAGIC 1-MMER
2	HAMMER LUG -WGP
3	NYLON PLUG
4	SET SCREW 1/4-28 UNF 3A X 3/8

SPARES & ACCESSORIES
Your marker comes with a spare parts kit. This includes:

 132524-000 132304-000	 135032-000 135016-000 142456-000	 132414-000 132296-000 135059-000 130885-000	 132401-000 132303-000
--	---	--	--

Additional repair for your ASR is available thru you local dealer or contact us directly.

Available upgrade:

1. 3pc Plastic Body Kit

Red: 1218

Red: 1219

Red: 1217

Red: 1220

For the player that likes their equipment looking slick, the SR Autococker® 3 piece Plastic Body Kit allows players to customize their marker. The kit includes the right body panel, left body panel and the solenoid cover.

2. Strip Kit

Red: 1230

Red: 1231

Red: 1231

Red: 1231

Make the SR Autococker® fully customized with the accessory that will turn heads and increase performance with its color enhanced soft grip. This SR Strip Kit is the perfect upgrade to ensure an effective and stylish marker.

Troubleshooting Guide

Troubleshooting

Always be sure that anytime you are working with your marker you are in a safe environment. A safe environment is an area where you and every one within 200 yards is wearing paintball approved safety goggles and equipment. Also be sure to empty all paintballs and exhaust all air from the marker before storing the marker in a secure locked place.

Note: A qualified technician should make all repairs and adjustments.

Do not attempt to perform any factory-only repairs. Call WGP for any service needed on your marker. Any damage caused by improper adjustments is not covered by the warranty.

1. Marker won't fire properly or has low velocity after removing and replacing bolt. Bolt installed upside down. Remove bolt. Reinstall after rotating 180 degrees. The hole side should be facing down.

2. Marker will not fire when trigger is pulled.

a. Marker OFF, turn marker ON

b. Battery low, replace battery

c. Gas source pressure low or tank empty. Fill tank.

d. Ensure inline HP regulator is adjusted to correct operating pressure.

e. LPR low, adjust higher.

3. Marker will not cock or cocks every other time or less

a. Pressure too low. Fill bottle or adjust regulator.

b. LPR regulator pressure set too low.

c. Timing lug out of adjustment.

d. Velocity adjustment set too high.

e. Side cock block or cocking rod adjustment incorrect.

f. Eyes may be OFF, turn marker eyes ON.

g. Timing on PCBA adjusted to far out, reset PCBA to factory settings.

4. Chops paintballs.

a. Break beam eyes blocked, check eyes.

b. Bad eyes, replace.

c. Loader is not feeding fast enough.

d. Ensure bolt clears breech fully. See side cock block and pump rod adjustment.

e. Paint is soft or swelled. Ensure that paint is not too large for barrel.

f. Old bad paint, replace paint.

g. Check loader and breech for foreign matter.

5. Leaking between tank valve and marker Bottom line Air Receiver.

a. Bad valve O-ring. Replace valve O-ring. This is the external O-ring at the top of the valve.

6. Low velocity

a. Gas source pressure too low or tank empty. Fill tank.

b. Improper IVG adjustment. Adjust velocity.

c. Regulator pressure too low or high. See sweet spotting the regulator section.

d. Check gas source. Make sure input pressure to marker is consistent.

e. Paint rolling down the barrel. Paint too small.

f. Bolt upside down.

g. Timing on PCBA adjusted to far out, reset PCBA to factory settings.

7. Gas leaks down the barrel

a. Hammer is resting on the valve stem. When you gas up the gun, always make sure to cock it first. When the hammer is forward, it will push the valve slightly, and hold it open. This can cause either a massive barrel leak if the input pressure doesn't force the valve closed, or a brief spurt of air as the pressure closes the valve.

b. Cup seal not seated correctly. In a safe environment, oil your marker and fire it a few times to help seat the valve. Fire marker a couple of times with out balls. The cup seal may reseal after a couple of shots. If you still hear excess air escaping from the marker, call WGP for service.

c. Cup seal dried out. Put 5-6 drops of paintball gun oil in the ASA, and shoot the gun until you can hold a paper towel over the breach, shoot, and it stays clean.

d. HP regulator is not set up correctly.

e. Bad cup seal, a replacement may be required.

f. Bad valve o-ring. Remove and replace exhaust valve. This should only be done with special-ized tools. Contact WGP.

8. Marker cycles slowly

a. Low pressure from regulator. Adjust.

b. Leaky ram. Replace or rebuild the ram.

c. Oil and re-lube the marker

d. Low tank pressure.

e. LPR set too low, adjust up.

f. Program speed limited, reset program to factory settings.

FAQ

Q) How do I safely maintain my WGP Autococker® marker?

A) Safely maintaining your marker is simple and easy. You need only clean and oil your marker to keep it up and running.

Q) How do I oil my marker?

A) You only need to lubricate your marker after every 4 to 5 days of play. To oil your maker you first, in a safe environment, remove your loader, then fire all excess paintballs out of the marker. Next remove your tank and fire all excess air from the marker. Now remove your barrel. Next drop 3 to 4 drops of either 3 in 1 oil or any other approved paintball marker oil into the air receiver and safely fire the marker 10-15 times. This will distribute the oil throughout the internals of the marker. At this time you can also lubricate your bolt O-rings. Be sure that the hole in between the 2 O-rings on your bolt is always facing down. Factory approved lubricants: Petroleum jelly, 3 in 1 oil and lithium grease.

Q) How do I safely clean my marker?

A) To clean your marker you first find a safe environment then remove your loader, then fire all excess paintballs out of the marker. Next remove your tank and fire all excess air from the marker. Now remove your barrel, then lightly spray down marker with a 50-50 mix of rubbing alcohol and water and then wipe it down with a clean cloth.

Q) Does WGP recommend CO2 or compressed air on the ASR?

A) WGP recommends compressed air. CO2 is not recommend since there is a possibility of over pressurizing and freezing the marker.

Q) Sometimes when I air up my marker, I hear air coming out of the barrel. What causes that?

A) Before you air up your marker always be sure to cock the marker first, this will take the pressure off of the valve and stop the air from escaping, if you still hear air escaping try oiling and firing the marker a few times in a safe environment to seat the valve. If you continue to hear air escaping, call WGP for service. It is not recommended to adjust or remove the hammer or hammer lug without proper training. See trouble shooting tips.

Q) What is timing? And do I need to adjust it?

A) Timing is the length of time between when your marker fires and when it starts to re-cock.

Your marker comes timed from the factory and should not need to be adjusted. It is not recommended to adjust or remove the hammer or hammer lug without proper training.

Q) I broke a paintball in my marker. How do I clean it?

A) To clean broken paintball out of your marker you will first remove your loader, next your tank be sure to fire all excess paintballs and air from your marker. Next remove your barrel

and then your bolt. Using a squeegee or battle swab, run it through the same chamber you pulled the bolt from, then run it through the barrel. Reinstall the bolt. Be sure that the hole in between the 2 o-rings on your bolt between the 2 o-rings is facing down and you're ready to go.

Q) I've removed my bolt and replaced it, and my velocity has dropped. What is the problem?

A) Any time you remove the bolt from your marker, you must always be sure that the hole in between the 2 O-rings on your bolt is always facing down before reinstallation. This is common problem that could directly affect the velocity of your marker.

Q) What is the reason to have different barrel sizes?

A) The reason for using different barrel sizes is, paintballs are different sizes due to freshness, weather and other factors. By having different barrel sizes your will be able to match your paint to your barrel to get the best accuracy and consistency out of your marker.

Q) I have a question that is not on this list. What do I do?

A) If you have more questions and did not find the answers here, Please contact WGP directly.

Or visit www.worr.com

International Service Center List List de Centre de Service Après-Vente International Lista de Centros de Servicio Internacionales

**Canada:
Kolder Canada
905.a.9191
sales@koldercanada.com**

**Europe:
JT Europe
49.6031.73.75.0
service@jt-europe.com**

**Mexico & Central America:
Xtreme Planet
55.5290.8190
servicio@xtremeplanet.com**

**South Africa:
Paintball City
27.11.828.7583
tech@paintballcity.co.za**

**New Zealand:
Kilwell Sports
07.345.9094
sports@kilwell.co.nz**

**South America:
Mercenarios Brazil
11.3871.1468
mercenarios@mercenarios.com.br**

WARRANTY INFORMATION

WARRANTY: LIMITED 90 DAY WARRANTY

(ORIGINAL PURCHASE RECEIPT REQUIRED)

For 90 days from date of purchase, Worr Games® will repair or replace this marker free of charge if defective in material or workmanship. This warranty gives you specific legal rights. You may also have other rights which may vary from state to state. Service is available from authorized Worr Games® Service Centers. A list of these is available at Worr Games® website at www.worr.com or by calling Worr Games® at 1.800.755.5061 These Service Centers gener-ally offer the quickest service.

If you would rather return your marker to Worr Games® please call customer service at 1.800.755.5061 for return authorization number and shipping address. (Authorization number must be visible on outside of ship-ping package to be accepted.)

Do not return any products via non-trackable services such as regular mail or parcel post. Such products may become lost and Worr Games® will not be responsible for replacement.

PAINTBALL MARKERS OUT-OF-WARRANTY

Authorized Service Centers will gladly repair any markers out of warranty for a nominal charge to cover parts and labor. Repairs made by Service Centers will usually be faster and less expensive than those sent back to the factory. Go to www.worr.com for service center locations near you. Prior to shipping out of warranty markers, you must first call customer service at 1.800.755.5061 for return authorization number and shipping address. (Authorization number must be visible on outside of shipping package to be accepted.) Any out of warranty Marker returned to Worr Games® must be shipped prepaid and include the repair fee. Please call the Customer Service number for current repair fees. Worr Games® will repair or replace the marker with a reconditioned unit of the same model. If payment is not included, you will be billed for the repair fee plus a \$4.00 invoicing fee. Upon receipt of payment, the marker or its replace-ment will be shipped to you. In the event that the marker includes no means of contacting the sender or no payment for repairs is received within 60 days of billing, the ownership of the marker will be forfeited and it will be disposed of at the discretion of Worr Games® Inc.



WORR GAME PRODUCTS
5818 El Camino Real
Carlsbad CA 92008
800 587 2246
worr.com